

# THE ENERGY RANGE

Everything you need  
to keep Britain glowing



**Glow•worm**

**Keeping Britain Glowing**

# KEEPING BRITAIN GLOWING

## We've been keeping people cosy for over 80-years

Our products are made for homes that are there to be lived in, not looked at. Whether it's the hot shower after football training or toasty socks straight off the radiator, we provide that warm glow that keeps everyone going. You'll love our products too – they're easy to fit, reliable and backed by exceptional support, with more perks than you can shake a spanner at.



Rated **Excellent** on ★ **Trustpilot**

## Who we are

Glow-worm is a cornerstone of the UK heating industry, nestled in the heart of Derbyshire. Since 1934, our focus has been on building robust, high-efficiency boilers, controls, and accessories that provide the families of Britain with the warmth and hot water they need, when they need it.

In 2001, we were acquired by the Vaillant Group, one of Europe's largest heating appliance manufacturers. Its investment has enabled us to expand our product offering and develop innovative new technologies – while keeping our roots at our state-of-the-art factory in Belper.

As part of Vaillant Group, Glow-worm is proud to have achieved both Investors in People Gold and Health and Wellbeing awards.



INVESTORS  
IN PEOPLE

Gold  
Until 2022



Investors  
in People

Health &  
Wellbeing  
Award

# Say hello to the Energy range

Our Energy boiler range offers attractive modern design, easy-to-use interfaces and a great choice of models and controls. Its lightweight, compact construction makes life easy for you, while its long-lasting, quiet performance is a hit with homeowners too.

## Benefits:

- Ultra-reliable performance and a guarantee of up to 10-years provide dependability customers crave
- Top and rear flue options offer flexible siting
- Wide product range means there's an Energy for virtually any installation
- Cupboard fit dimensions and a small footprint for easier installation
- Modulating Grundfos pump delivers lower running costs
- Automotive-grade aluminium heat exchanger lasts longer and reduces bills
- Bright LCD is easy-to-use in all conditions
- Quiet Mark approval keeps homeowners happy
- Works with Glow-worm's entire range of intelligent controls

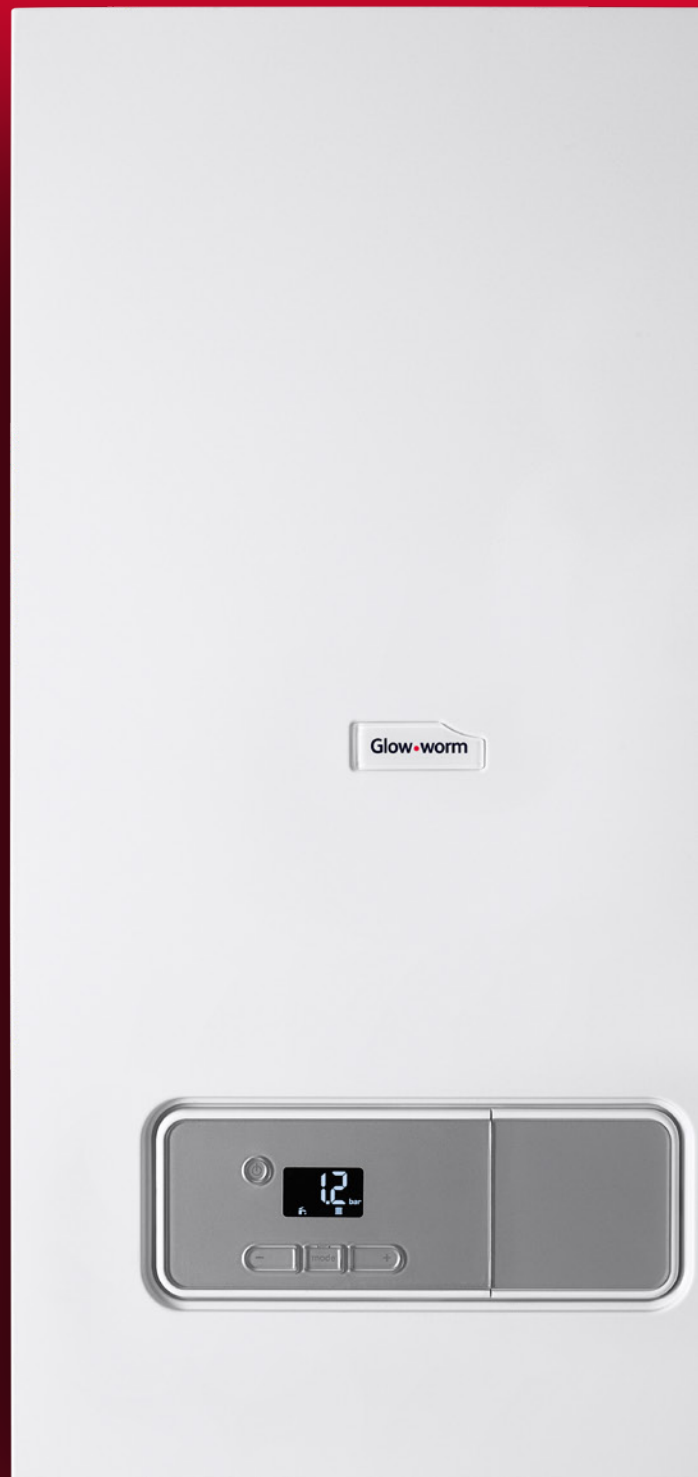

# Energy Combi Boiler

Our Energy Combi range combines an attractive modern design with exceptional performance. Light and compact, with a choice of top or rear flues, it's a dream to fit. The automotive-grade aluminium heat exchanger has large waterways that make it ideal for retrofit jobs, and with simple tools or chemicals. Patented four-sided cooling reduces the strain on the heat exchanger to improve reliability. Homeowners will love the extra reassurance of a guarantee of up to 10-years.

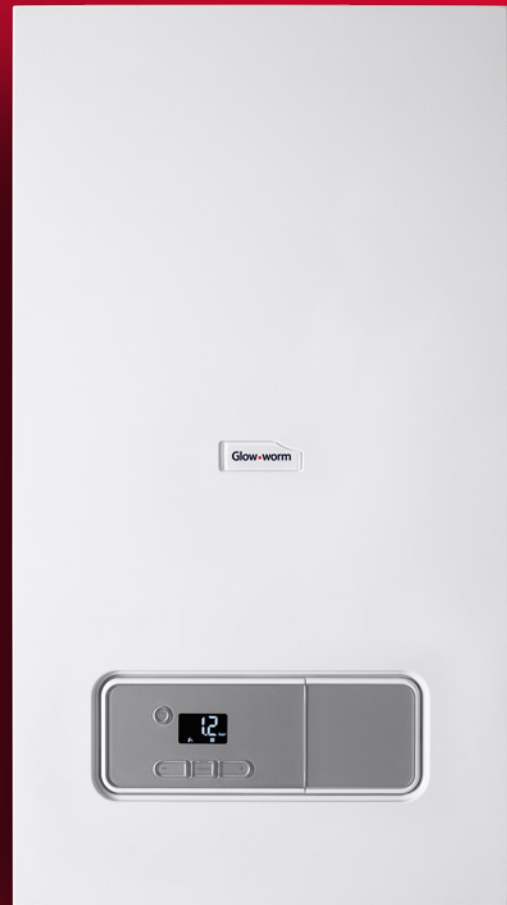

FREE 10-year guarantee\*



Earn cashback when installs are registered through Club Energy

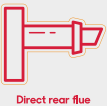

Direct rear flue



Manufactured in our award-winning factory in Derbyshire



Ultra-quiet operation

## Features and benefits

- Quiet Mark approval means ultra-quiet operation for homeowners
- Superior-quality parts last longer, are easier to maintain, and help reduce energy bills
- Small footprint can be installed in more locations, including kitchen cupboards
- Modern LCD offers excellent clarity, even in dimly lit rooms
- Top and rear flue options give you flexibility when fitting
- Works with Glow-worm's entire range of intelligent controls

\*When installed with a Glow-worm Power System filter and registered through Club Energy.

# Energy Combi technical specification

## Energy Combi dimensions

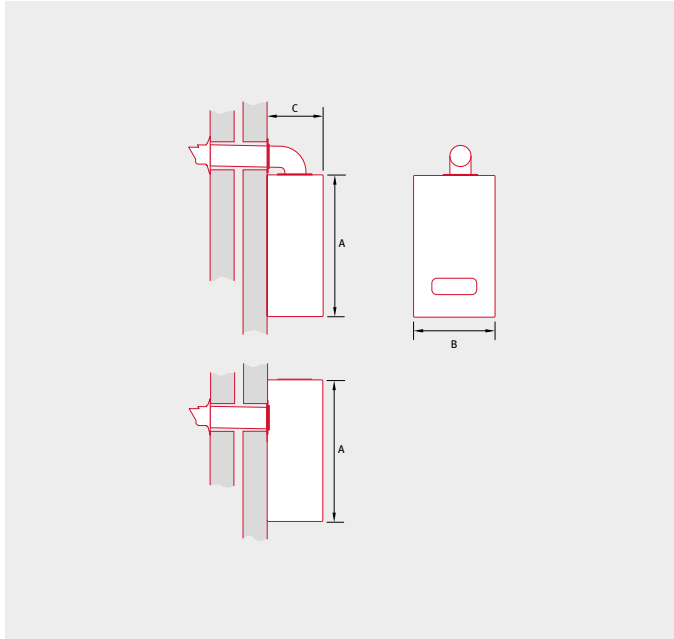

**Boiler dimensions**

Height (A)	Width (B)	Depth (C)
700mm	390mm	280mm

## Energy Combi clearances

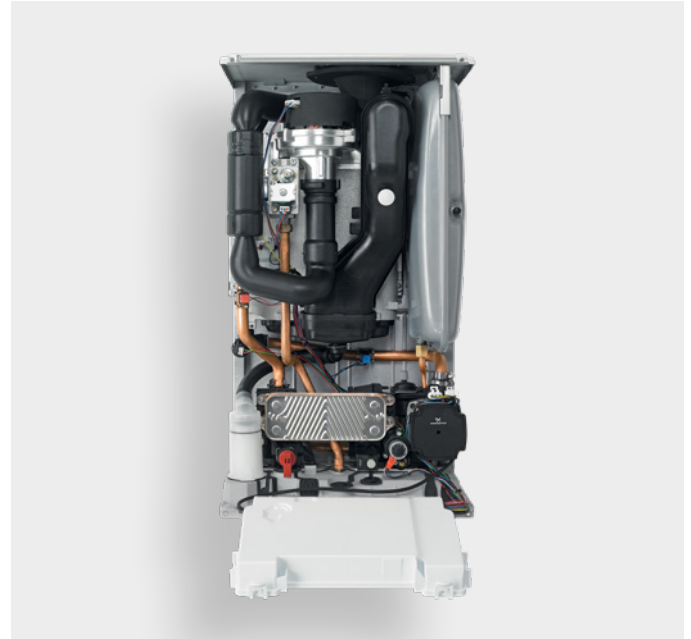

**Boiler clearances**

Top	Side	Bottom	Front
150mm*	5mm	150mm	600mm

\*Reduced to 20mm if using a rear flue

Energy Combi boilers	Unit of measure	25c	30c	35c
<b>General</b>				
Boiler type		Combi	Combi	Combi
Model output	kW	25	30	35
Article number		00 10015652	00 10015653	00 10015654
Gas Council number		47-019-24	47-019-25	47-019-26
<b>Performance</b>				
NOx (En 15502-2-1)	mg/kWh	39	39	39
ErP efficiency Heating/DHW – (A+++ to D / A+ to F)	A+++ to D / A+ to F	A/A	A/A	A/A
ErP decibel rating (sound power)	dBa	49	51	52
PCDB seasonal efficiency	%	89.2	89.2	89.2
<b>Heating and Hot Water</b>				
Hot water flow rate	L/min	10.4	12.2	14.1
Lift weight	kg	32	33	33
Max flue length - horizontal/vertical	M	10/10	10/10	10/10
Rear flue	Yes/No	Yes	Yes	Yes

# Energy System Boiler

Our Energy System boilers are great for homes with high hot water demands and can be installed with a range of cylinders for hot water storage. Light and compact, yet perfectly formed, it's a breeze to fit, especially with its choice of top or rear flues. Servicing is easy too, with simple water flush cleaning that doesn't need any special tools or chemicals. The combination of automotive-grade materials and patented four-sided cooling means the heat exchanger lasts longer and gives homeowners the reliability they expect from their boiler. Plus, the nationwide availability of parts means they're easier to fix than an Italian football match.



FREE 10-year guarantee\*



Earn cashback when installs are registered through Club Energy



Direct rear flue



Manufactured in our award-winning factory in Derbyshire



Ultra-quiet operation

## Features and benefits

- Quiet Mark approval means ultra-quiet operation for homeowners
- Superior-quality parts last longer, are easier to maintain, and help reduce energy bills
- Small footprint can be installed in more locations, including kitchen cupboards
- Modern LCD offers excellent clarity, even in dimly lit rooms
- Top and rear flue options give you flexibility when fitting
- Works with Glow-worm's entire range of intelligent controls

\*When installed with a Glow-worm Power System filter and registered through Club Energy.

# Energy System technical specification

## Energy System dimensions

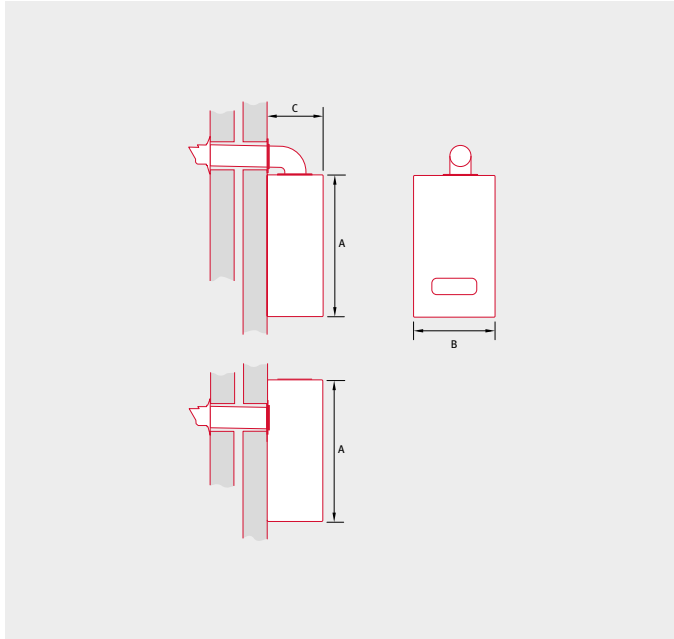

**Boiler dimensions**

Height (A)	Width (B)	Depth (C)
700mm	390mm	280mm

## Energy System clearances

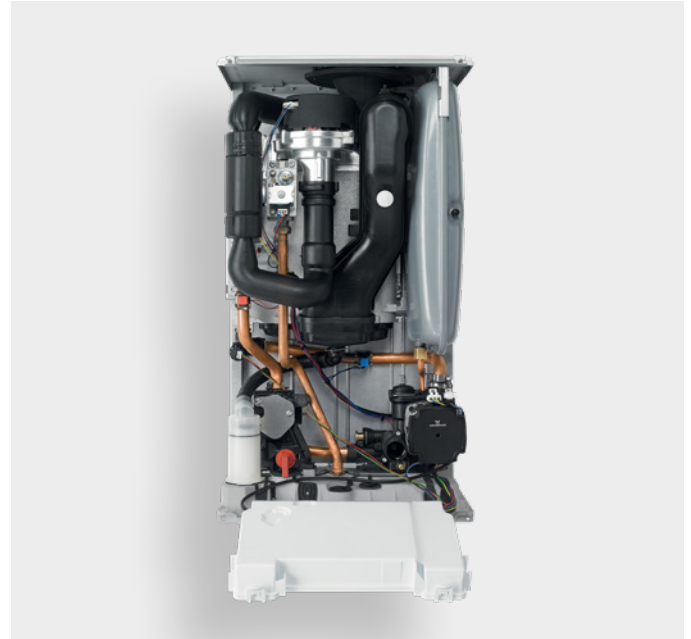

**Boiler clearances**

Top	Side	Bottom	Front
150mm*	5mm	150mm	600mm

\*Reduced to 20mm if using a rear flue

Energy System boilers	Unit of measure	12s	15s	18s	25s	30s
<b>General</b>						
Boiler type		System	System	System	System	System
Model output	kW	12	15	18	25	30
Article number		0010015655	0010015656	0010015657	0010015658	0010015659
Gas Council number		41-019-16	41-019-17	41-019-18	41-019-19	41-019-20
<b>Performance</b>						
NOx (En 15502-2-1)	mg/kWh	36	37	39	39	40
ErP efficiency Heating/DHW – (A+++ to D / A+ to F)	A+++ to D / A+ to F	A/-	A/-	A/-	A/-	A/-
ErP decibel rating (sound power)	dBa	45	47	49	51	54
PCDB seasonal efficiency	%	89.3	89.3	89.3	89.3	89.2
<b>Heating and Hot Water</b>						
Lift weight	kg	31	31	31	32	32
Max flue length - horizontal/vertical	M	10/10	10/10	10/10	10/10	10/10
Rear flue	Yes/No	Yes	Yes	Yes	Yes	Yes

# Energy Regular Boiler

Our Energy Regular open vent boiler can be paired with a wide range of controls to create the perfect heating system for homeowners. It's especially useful for those shower junkies and radiator hogs with high hot water demands and can be installed with a range of cylinders for hot water storage. Despite its heavyweight performance, the Energy Regular is lightweight, compact and easy to install. The choice of top or rear flue offers flexibility, particularly when it comes to retrofitting. We use patented four-sided cooling to reduce stress on the high-quality heat exchanger, delivering reliability homeowners can really get behind.



FREE 10-year guarantee\*



Earn cashback when installs are registered through Club Energy

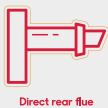

Direct rear flue



Manufactured in our award-winning factory in Derbyshire

## Features and benefits

- Superior-quality, automotive-grade heat exchanger lasts longer, is easier to maintain, and helps reduce energy bills
- Easy heat exchanger cleaning - simply flush with water
- Small footprint can be installed in more locations, including kitchen cupboards
- Modern LCD offers excellent clarity, even in dimly lit rooms
- Top and rear flue options give you flexibility when fitting
- Works with Glow-worm's entire range of intelligent controls

\*When installed with a Glow-worm Power System filter and registered through Club Energy.

# Energy Regular technical specification

## Energy Regular dimensions

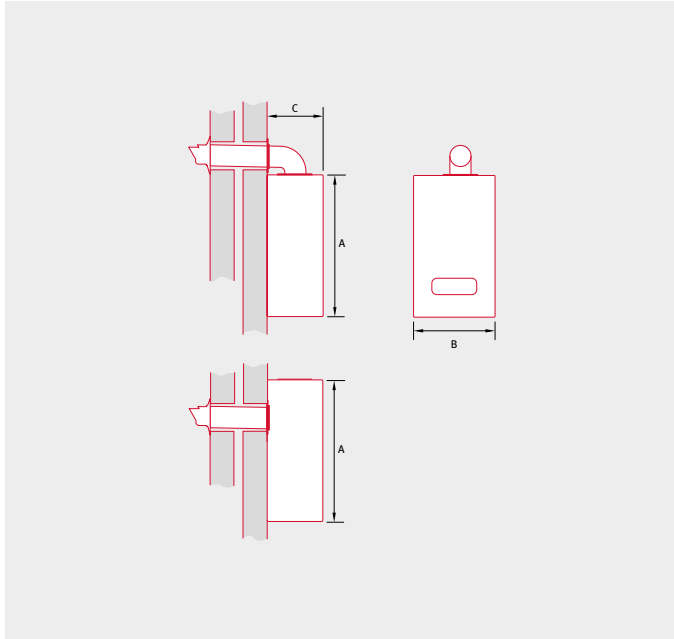

**Boiler dimensions**

Height (A)	Width (B)	Depth (C)
600mm	375mm	280mm

## Energy Regular clearances



**Boiler clearances**

Top	Side	Bottom	Front
150mm*	5mm	150mm	600mm

\*Reduced to 20mm if using a rear flue

Energy Regular boilers	Unit of measure	12s	15s	18s	25s	30s
<b>General</b>						
Boiler type		Regular	Regular	Regular	Regular	Regular
Model output	kW	12	15	18	25	30
Article number		00 10015660	00 10015661	00 10015662	00 10015663	00 10015664
Gas Council number		41-019-16	41-019-17	41-019-18	41-019-19	41-019-20
<b>Performance</b>						
NOx (En 15502-2-1)	mg/kWh	33	32	39	39	39
ErP efficiency Heating/DHW – (A+++ to D / A+ to F)	A+++ to D / A+ to F	A/A	A/-	A/-	A/-	A/-
ErP decibel rating (sound power)	dBa	47	47	49	51	52
PCDB seasonal efficiency	%	89.3	89.3	89.3	89.2	89.2
<b>Heating and Hot Water</b>						
Lift weight	kg	22	22	22	22	22
Max flue length - horizontal/vertical	M	10/10	10/10	10/10	10/10	10/10
Rear flue	Yes/No	Yes	Yes	Yes	Yes	Yes

# Energy 35 Store Boiler

The Energy 35 Store boiler offers the best of both worlds, combining the benefits of System and Combi boilers into one fully integrated package. Its ability to provide instant, unlimited domestic hot water makes it perfect for big homes with high demand. Two 21 litre insulated tanks housed inside the unit provide a lightning-quick re-heat time of under five minutes and significantly reduce heat loss. With its stainless steel heat exchanger, it also ensures a durable long-lasting performance. And because there's no need to put in a hot water cylinder, complexity, installation time and costs are all reduced.

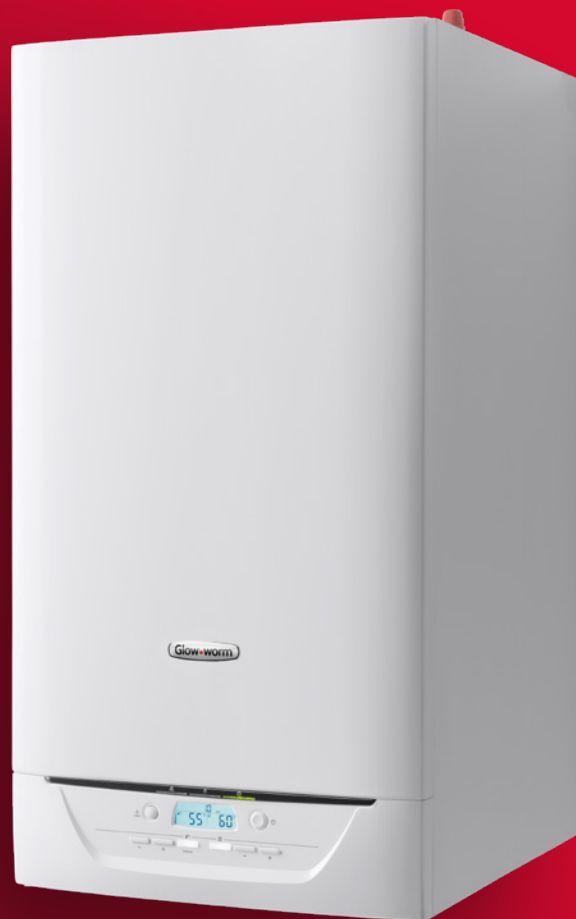

FREE 10-year guarantee\*



Earn cashback when installs are registered through Club Energy



Manufactured in our award-winning factory in Derbyshire

## Features and benefits

- High-performance heating and instant hot water keep homeowners happy
- High-efficiency Combi Store technology delivers regeneration times of under five minutes
- High flow rate fills baths and sinks quickly so homeowners aren't left waiting around
- Modulating Grundfos pump adapts to demand to improve efficiency
- LPG compatibility provides more siting options for off-grid properties
- Lower installation cost and less space needed than system boilers
- Works with Glow-worm's entire range of intelligent controls

\*When installed with a Glow-worm Power System filter and registered through Club Energy.

# Energy 35 Store technical specification

## Energy 35 Store dimensions

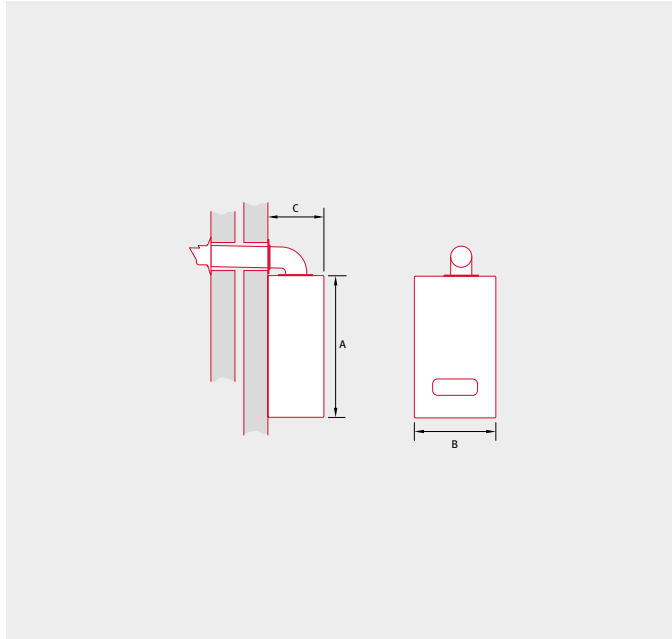

**Boiler dimensions**

Height (A)	Width (B)	Depth (C)
890mm	470mm	561mm

## Energy 35 Store clearances



**Boiler clearances**

Top	Side	Bottom	Front
300mm	50 (l) 150 (R)	300mm	600mm

Energy 35 Store boiler	Unit of measure	35 store
<b>General</b>		
Boiler type		Combi store
Model output	kW	35
Article number		0010017338
Gas Council number		47-019-37
<b>Performance</b>		
NOx (En 15502-2-1)	mg/kWh	40
ErP efficiency Heating/DHW – (A+++ to D / A+ to F)	A+++ to D / A+ to F	A/A
ErP decibel rating (sound power)	dBa	51
PCDB seasonal efficiency	%	89.4
<b>Heating and Hot water</b>		
Hot water flow rate	L/min	23*
Nominal heat output range at 50/30°C (condensing mode)	kW	9.3 - 31.5
Nominal heat output range at 80/60°C (non condensing mode)	kW	8.5 - 30
Maximum flow temperature	°C	80
Lift weight	kg	67
<b>Flueing options</b>		
Rear flue options	Yes/No	No

\*at 30 degrees C temperature rise

# Energy LPG Combi Boiler

Quiet, compact and discreet, our highly efficient Energy LPG 30kW Combi boiler comes with the protection of a 10-year guarantee for long-lasting cosiness. Easy to install, maintain and service, it reduces running costs and offers ultra-quiet operation to increase comfort for homeowners. Its compact size makes it the perfect solution for replacing boilers in park homes.

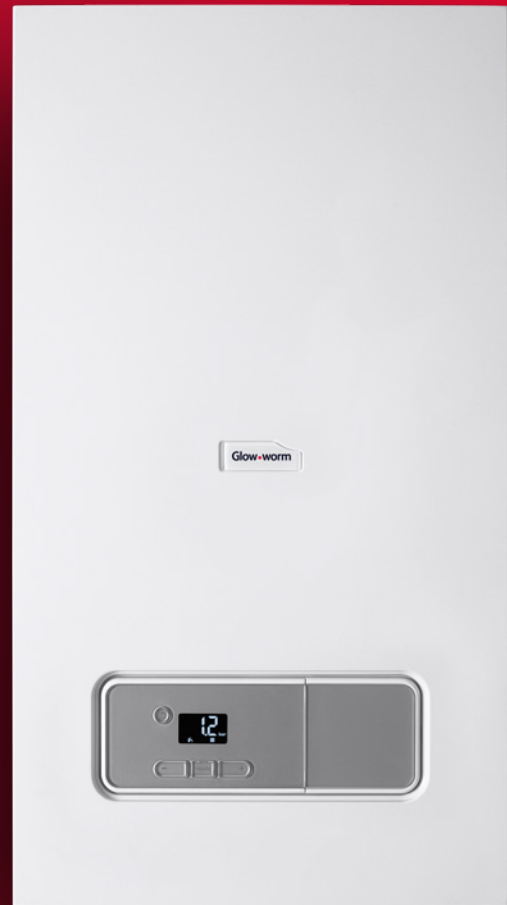

FREE 10-year guarantee\*



Earn cashback when installs are registered through Club Energy

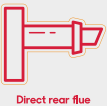

Direct rear flue



Manufactured in our award-winning factory in Derbyshire



Ultra-quiet operation

## Features and benefits

- Supplied with top, rear and vertical flue options for easy installation
- Quiet Mark approval keeps things peaceful for homeowners
- High-grade aluminium heat exchanger lasts longer, is easy to maintain and lowers energy bills
- Small footprint can be installed in more locations, including kitchen cupboards
- Dedicated LPG model doesn't require any adjustments, allowing quicker and easier installation
- Modulating Grundfos pump adapts to demand to improve efficiency
- Works with Glow-worm's entire range of intelligent controls

\*When installed with a Glow-worm Power System filter and registered through Club Energy.

# Energy LPG Combi technical specification

## Energy LPG Combi dimensions

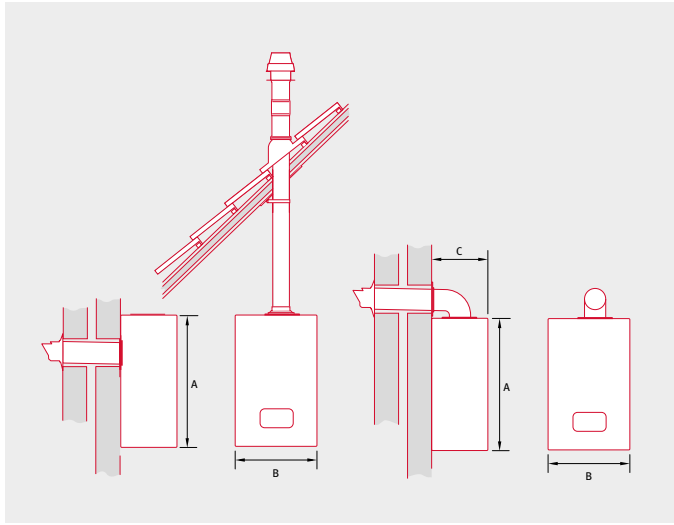

**Boiler dimensions**

Height (A)	Width (B)	Depth (C)
700mm	390mm	280mm

## Energy LPG Combi clearances

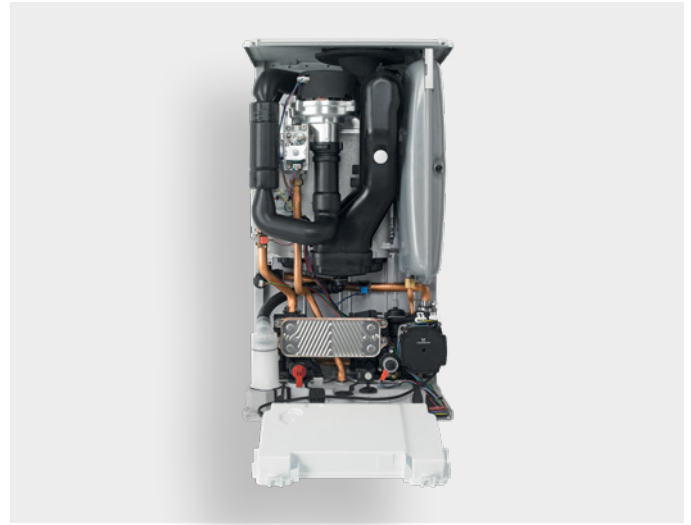

**Boiler clearances**

Top	Side	Bottom	Front
150mm*	5mm	150mm	600mm

\*Reduced to 20mm if using a rear flue

Energy LPG Combi boiler	Unit of measure	30c
<b>General</b>		
Boiler type		Combi
Model output	kW	30
Article number (rear flue pack)		00 10030436
Article number (vertical flue pack)		00 10031996
Article number (top flue pack)		00 10028635
Gas Council Number		47-019-38
<b>Performance</b>		
NOx (En 15502-2-1)	mg/kWh	35
ErP efficiency Heating/DHW – (A+++ to D / A+ to F)	A+++ to D / A+ to F	A/A
ErP decibel rating (sound power)	dBa	51
PCDB seasonal efficiency	%	91
<b>Heating and Hot Water</b>		
Hot water flow rate	L/min	12.4
Lift weight	kg	33
Rear flue	Yes/No	Yes
<b>Flueing Options</b>		
Maximum horizontal rear flue length 60/100	mm	70
Maximum horizontal flue length 60/100	mm	100
Maximum vertical flue length 60/100	mm	140

# A decade of positive Energy guaranteed

Our Power System Filter has been designed to give you even more confidence in the reliability of our products. Its compact yet robust build helps prolong the life of our boilers and deliver the long-term performance homeowners desire.

We're backing up this reliability pledge with a 10-year guarantee on Energy boilers and Power System Filters when they're installed together and both registered through Club Energy. Servicing is a cinch, and replacement O-rings are available as a spare part.

Designed by Glow-worm for use with Glow-worm boilers



FREE 10-year guarantee\*



Manufactured in our award-winning factory in Derbyshire

\*10-year guarantee only applies when filter is fitted on an energy boiler and registered on Club Energy

## What's in the box?

The Glow-worm Power System Filter comes with an installation and operational manual, and an isolation valve.

## Benefits and features

- Horizontal siting provides a more discreet, space-saving fit
- Compact design allows more flexible, less intrusive siting options
- High-quality brass body guarantees long-lasting performance
- Composite front section removes unnecessary weight
- Easy disassembly makes servicing faster
- Hard wearing stainless steel mesh that collects non-magnetic debris and blocks sludge from entering the boiler
- Suitable for boilers located in any situation
- Perfect for boilers installed in cold situations where glycol has been added to protect from freezing
- Can connect to a standard hose, so the drain point can also be used for dosing. The unique sealing ring and swivel head allows it to rotate without leaking for easier serviceability
- Ideal for modern systems as well as older, high-temperature systems

# Power System Filter technical specification

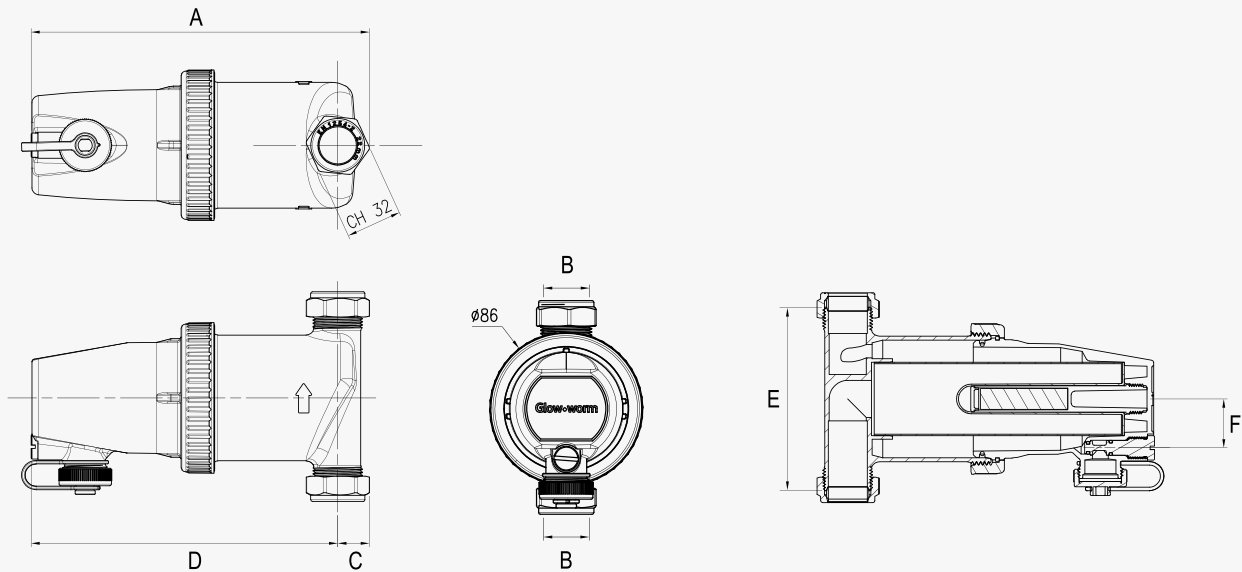

Technical data	Unit	Power System Filter
22mm fitting only		
A	mm	194
B	mm	22
C	mm	18
D	mm	176
E	mm	105
F	mm	28

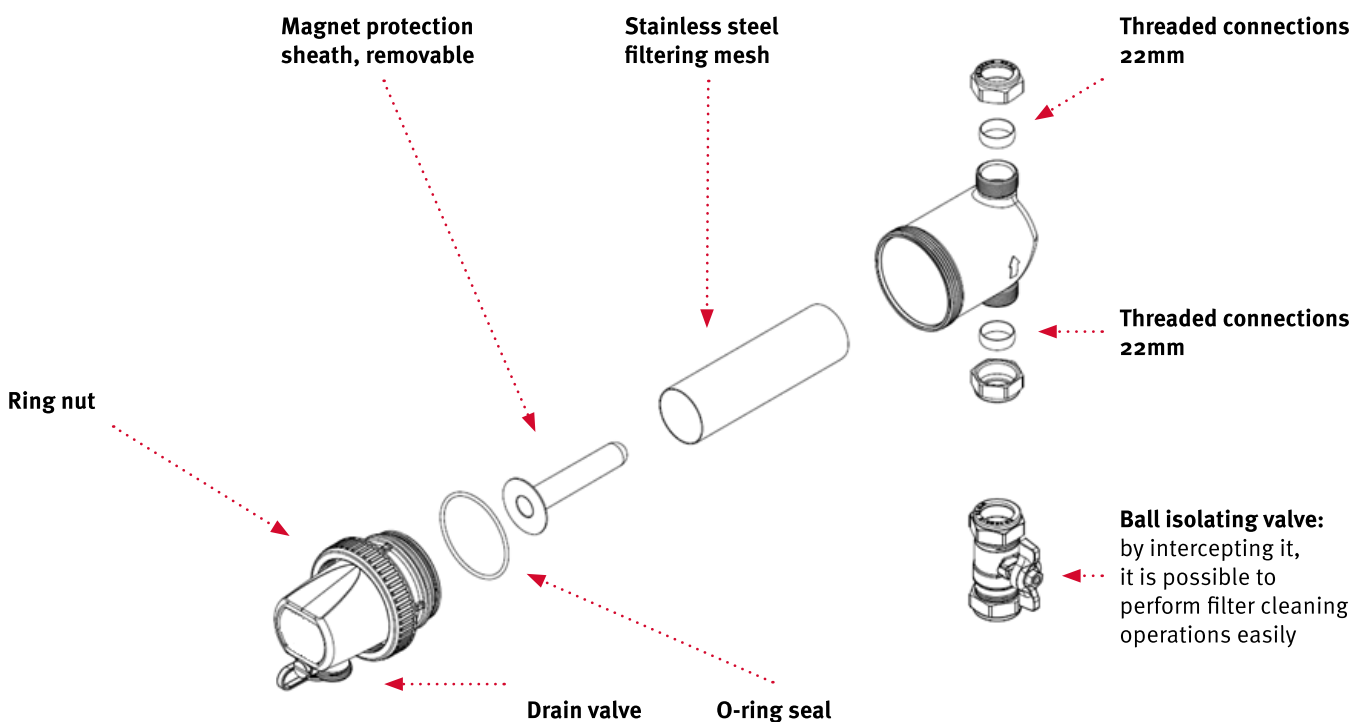

# Intelligent controls: Putting comfort in homeowners' hands

Glow-worm's wide range of controls has something to suit every customer, from simple room thermostats to wireless, app-controlled options. You'll enjoy the easy fitting while homeowners will love the convenience and comfort they offer. When added to a Combi boiler, our intelligent controls also help you comply with Boiler Plus legislation. What's more, our controls get the same guarantee as any Energy boiler when fitted together, just as long as they are registered on Club Energy (see page 19 for more details).

## MiGo

### Key features:

- Smart thermostat and app combination
- Easy-to-use app allows homeowners to control their heating from anywhere
- Fast, simple installation lets you get in and out without shaking it about
- Internet weather compensation optimises system flow temperatures and efficiency
- Unique eBUS communication works with the entire Glow-worm boiler range
- Intelligent self-learning analyses the thermal behaviour of the building so homeowners always get the temperature they ask for



## MiSet

### Key features:

- Wall-mounted programmable room thermostat
- Responsive touch interface makes it easy to manage heating
- Time program assistant helps homeowners set heating programs in minutes
- User-friendly operation for hassle-free heating adjustments
- Enhanced load compensation adjusts output to ensure efficient energy usage
- Available as a wired or wireless model

# Climastat

## Key features:

- Wall-mounted room thermostat
- Enhanced load compensation ensures energy-efficient boiler use via eBUS connection
- Combines with mechanical timers to provide low-cost Boiler Plus compliance
- Service, fault and maintenance indication for convenience
- Clear digital display and wide temperature range (5-30°C) makes life easy for homeowners



# Climapro<sub>1</sub>

## Key features:

- Programmable thermostat available in wired and wireless models
- eBUS connection enables modulation to provide peak boiler performance and efficiency
- Weather compensation (with additional sensor) automatically keeps homeowners cosy when it gets colder
- User-friendly operation for hassle-free heating adjustments



# Climapro<sub>2</sub> RF

## Key features:

- Two-channel wireless programmable room thermostat
- Handheld remote gives homeowners complete control of their heating and hot water from the comfort of their armchair
- Weather compensation (with additional sensor) automatically keeps homeowners cosy when it gets colder
- Straightforward menus allow homeowners to easily set their heating to suit their lifestyle and timetable
- eBUS connection lets the boiler modulate to deliver optimum efficiency



# Accessories for every home

Our innovative collection of Glow-worm Energy boiler accessories means you can give your customers exactly what they need. The wide range of thermostats and sensors with easy-to-master control systems gives customers total control over the temperature of their home, so they can have it just how they like it.



Part number	Description
0010031041	Horizontal flue kit DN 60/100
0010031043	Horizontal telescopic flue kit DN 60/100
0010031044	Horizontal flue kit 1.7m DN 60/100
0020219526	Rear telescopic flue kit DN 60/100
0020219538	Flue terminal kit, black
0020257015	Vertical flue adaptor DN 60/100
0020230604	Vertical flue terminal, black
0020199443	Flat roof flashing
0020258676	Pitched roof flashing
0020257007	Extension 0.5m DN 60/100 PP
0020257008	Extension 1.0m DN 60/100 PP
0020257445	Extension 2.0m DN 60/100 PP
0020267682	Extension 4.0m DN 60/100 PP
0020257009	Elbow 87 deg DN 60/100 PPv
0020257010	Elbow 45 deg DN 60/100 PP (2 pieces)
0020267923	Flue support clips 200mm DN 100 (5 pieces)
2000460487	Sliding sleeve DN 60/100
0020267683	Extension 0.5 to 0.8m telescopic 60/100 PP
0020267924	Flue support clips 100mm (pack of 5)
0020219531	Plume management kit black
0020219532	Plume management kit, white
0020219535	Plume deflector kit, black
0020219536	Plume deflector kit, white
0020219541	PMK extension 1m, black
0020219542	PMK extension 1m, white
0020219545	PMK elbow 87 deg, black
0020219550	PMK elbow 87 deg, white
0020257019	Extension 0.5m DN 80/125 PP
0020257020	Extension 1.0m DN 80/125 PP
0020257018	Horizontal air/flue DN 80/125 PP
0020257016	Roof terminal black DN 80/125 PP
0020104553	Extension 0.5m DN 80/125
0020104554	Extension 1.0m DN 80/125

Part number	Description
0020257021	Extension 2.0m DN 80/125 PP
0020257023	Elbow 87 deg DN 80/125 PP
0020257024	Elbow 45 deg DN 80/125 PP (2 pieces)
0020257022	Sliding Sleeve DN 80/125 PP
0020104559	Flue support clips (5 off) DN 60/100
0020276091	Vertical flue adaptor DN 80/125
0020193663	Upward piping kit
A2044800	Condensate pump
0020193659	Pipe cover plate, small
0020193660	Spacing frame, small
0010035820	Glow-worm Power System Filer
0010037590	Seal Kit
<b>MiSet</b>	
0020260999	MiSet (wired)
0020261004	MiSet (wireless)
0020260987	SR 92 (wired)
0020135101	Smart wiring centre3
0020266792	Outdoor sensor, with packing + 15m cable
0020266793	Outdoor sensor, with packing

# Boiler Plus

Boiler Plus legislation is designed to ensure that heating systems in all UK households are as energy efficient as possible. It requires new gas boiler installations to meet a minimum Energy Related Products (ErP) rating of 92%. You can do this by ensuring the correct time and temperature controls are fitted to heating systems at the time of installation. You can also retrofit them to existing systems. It's easy to comply with Boiler Plus by fitting a Glow-worm control with at least one of these features:

- Load compensation: the ability to use the current room temperature to modulate the flow temperature (this needs the control and boiler to communicate intelligently).
- Weather compensation: uses weather forecast data or outdoor sensors to understand the outside temperature and adjust the flow temperature of the boiler accordingly.
- Smart control: an internet-connected control that provides automated heating, hot water and optimised boiler efficiency.

Glow-worm offers you a wide range of dependable, intelligent and easy to install control solutions to help you meet Boiler Plus requirements. Take a look at the features table below or see the range in more detail on pages 16 & 17.

## Range line-up



	Climastat	Climapro <sub>1</sub>	Climapro <sub>2</sub> RF	MiGo	MiSet
Article Numbers	0020035402	0020118077 (wired) 0020118078 (wireless)	0020085221	0020223275 (combi) 0020223276 – (OV/System)	0020260999 (wired) 0020261004 (wireless)
Room thermostat	✓				
Programmable thermostat		✓	✓		✓
Internet connected				✓	
eBus communication	✓	✓	✓	✓	✓
Load compensation	✓	✓	✓	✓	✓
24-hour timer		✓	✓	✓	✓
7-day programming		✓	✓	✓	✓
Heating	✓	✓	✓	✓	✓
Hot water		✓	✓	✓	✓
Holiday mode		✓	✓	✓	✓
Wired or wireless	Wired	Wired or Wireless	Wireless	Wireless	Wired or Wireless
Weather compensation		✓*	✓*	✓	✓*
Remote app control				✓	
ErP efficiency class	V	V	V	VI	V
ErP efficiency benefit	+3%	+3%	+3%	+4%	+3%
Zoning	1	2**	1	1	2**

\* Weather compensating with additional outdoor sensor

\*\* 2 zones only achievable with wired models only

# Flueing options

## Horizontal top side flue (standard)

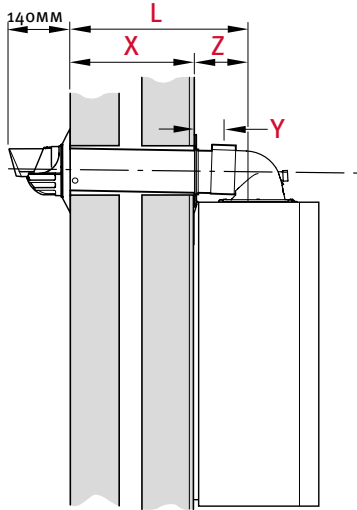

L = Flue length, measured from outside wall face to centre line of flue outlet.

X = Wall thickness.

Y = Distance from wall to edge of air duct on flue elbow.

Z = Distance from centre line of flue outlet to inside wall face.

The maximum flue length with extensions must not be exceeded (refer to L in table below). For each additional 90° or 2 x 45° bends fitted, the maximum flue length must be reduced by 1m. The pipe length is reduced by 500mm for each 45° elbow and 1m for each 87° elbow used.

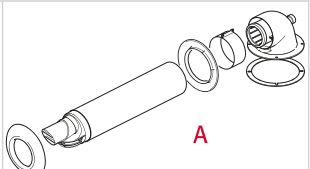
Model	L Max with extensions	X (mm)		Y (mm)	Z (mm)	Horizontal standard flue 0010031041*
		Min	Max			
Energy	10m	75	645	65	150	

\*White terminal as standard, for black terminal use 0020219538

### Horizontal accessories

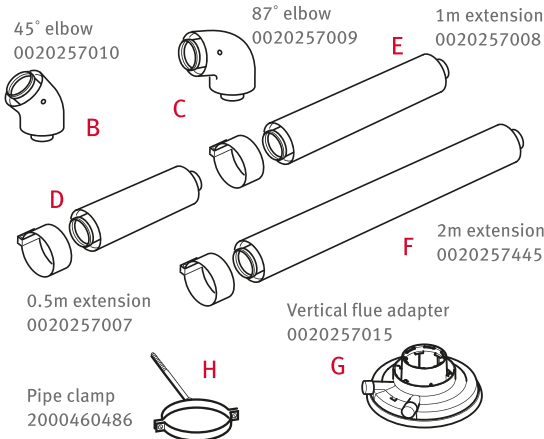

### Flueing examples using extensions and bends

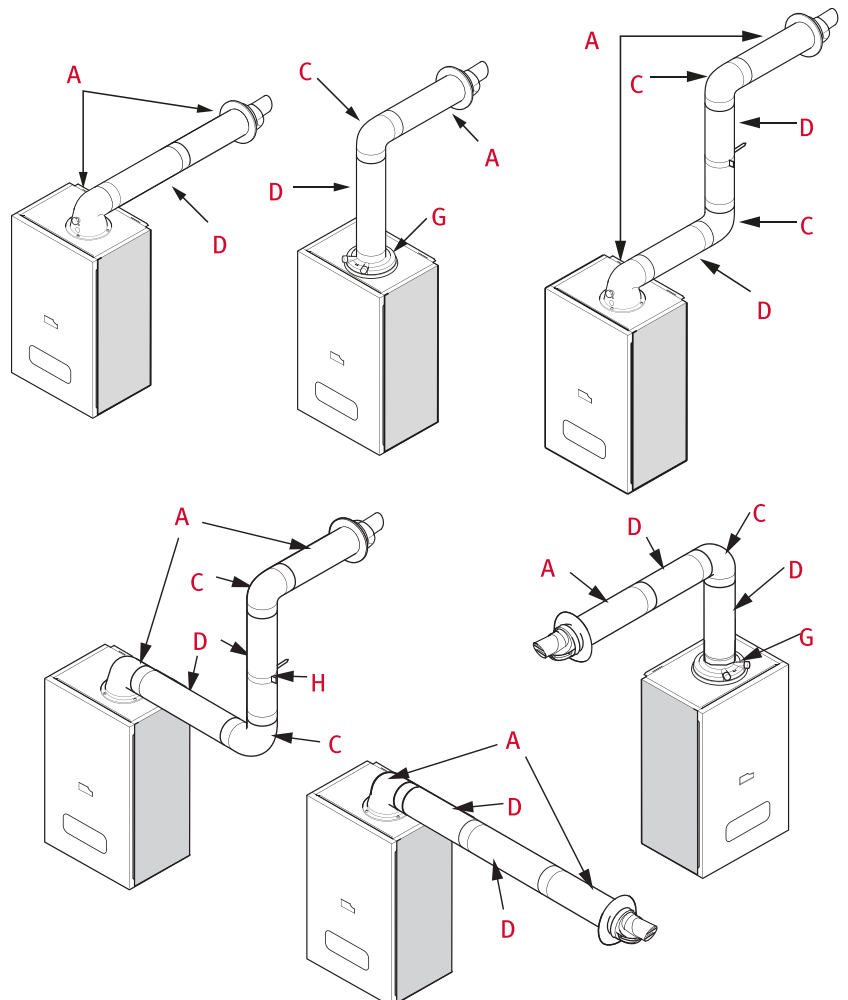

# Rear flue option

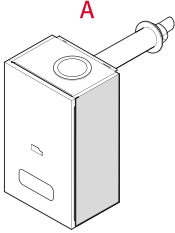
	Model	Max extensions	Min	Max	A Direct rear flue 0020219526
	Energy	No extensions	480	710	

Black terminal only

# Vertical flue options

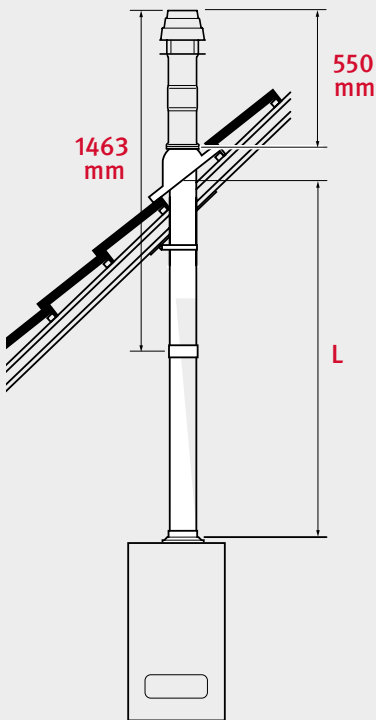

L = Flue length, measured from the top of the boiler to the underside of the roof flashing.

Maximum flue length is 10m plus external vertical roof terminal.

The maximum flue length must not be exceeded (refer to L in table below).

For each additional 90° or 2 x 45° bends fitted, the maximum flue length must be reduced by 1m. The pipe length is reduced by 500mm for each 45° elbow and 1m for each 87° elbow used.

Vertical flue options use the same 100mm diameter flue components as the horizontal flue options.

The vertical flue adaptor G is required for vertical installations.

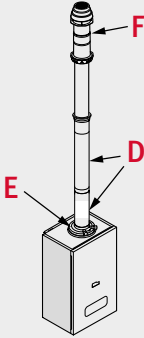
	Model	L Max with extensions	Description of parts	Part number
	Energy	10m	0.5m extension	0020257007
			1m extension	0020257008
			2m extension	0020257445
			Vertical flue adaptor	0020209763
Vertical flue terminal, black			0020230604	

## Vertical accessories

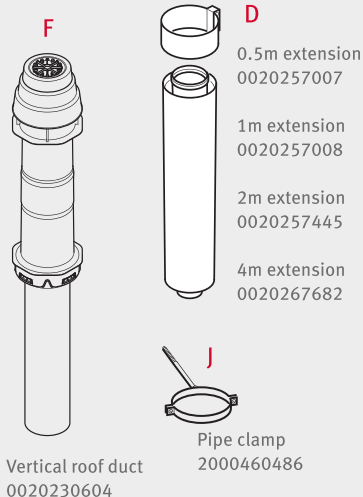

## Flueing examples using extensions and bends

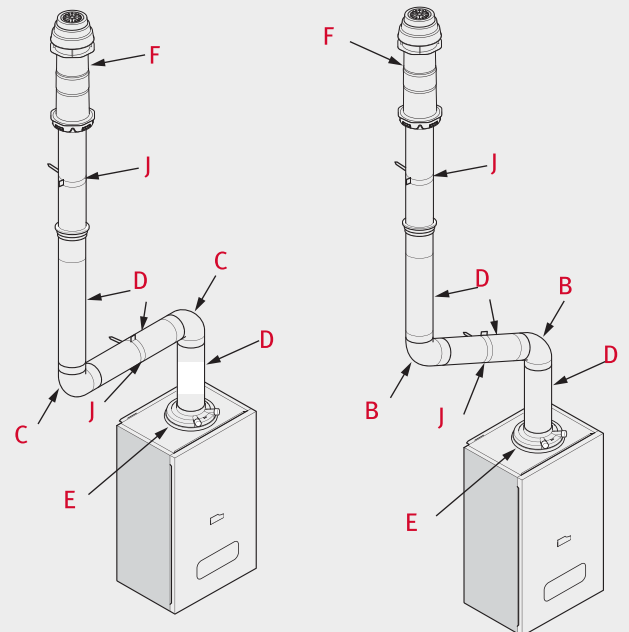
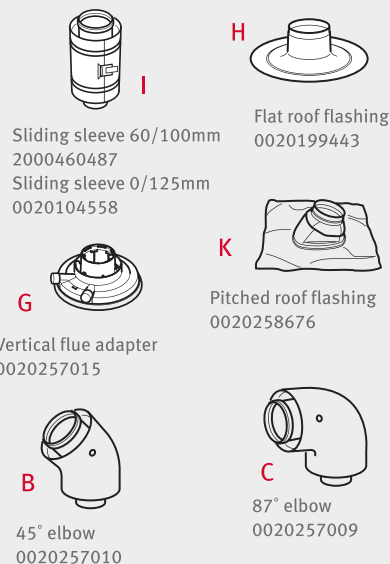



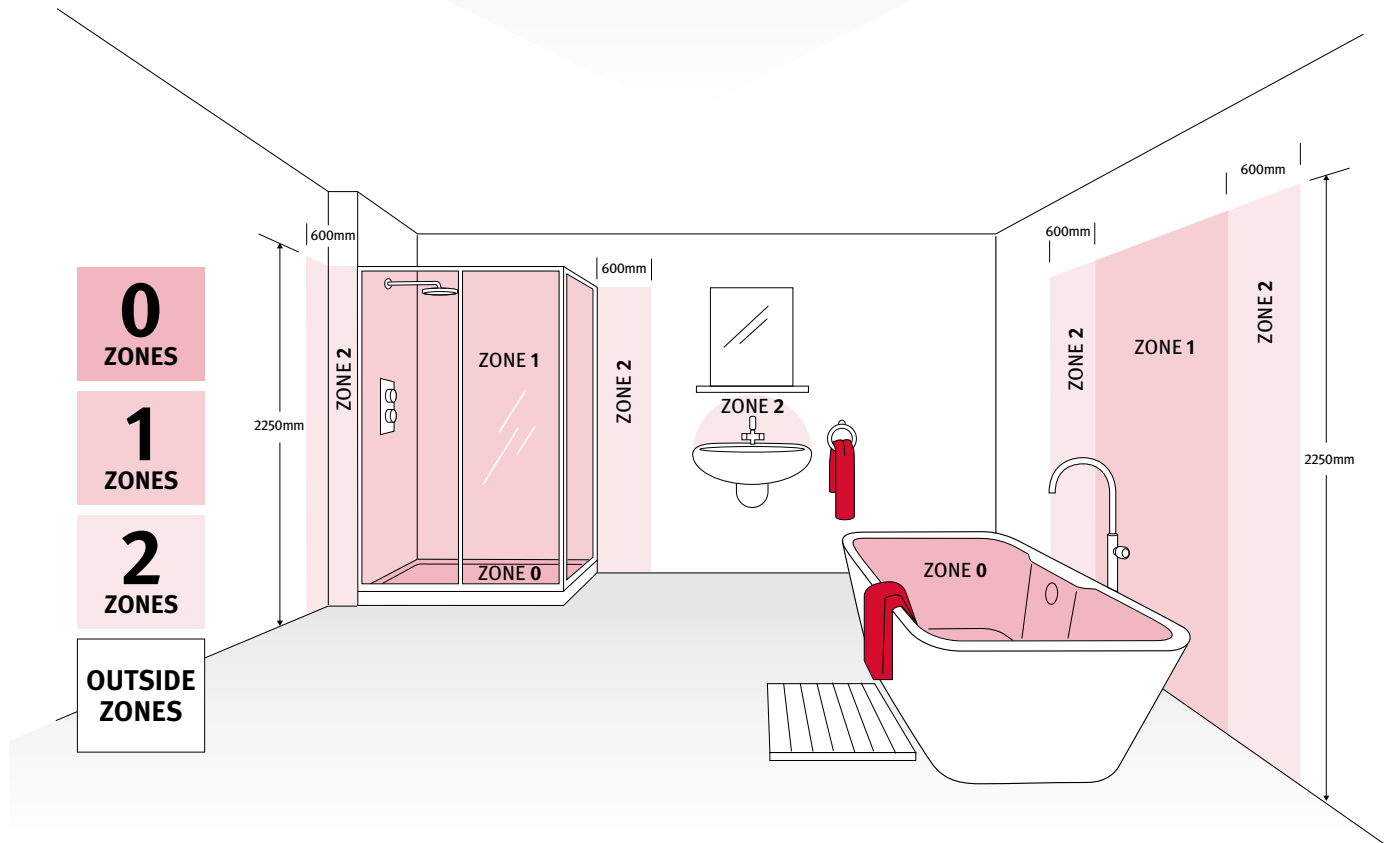
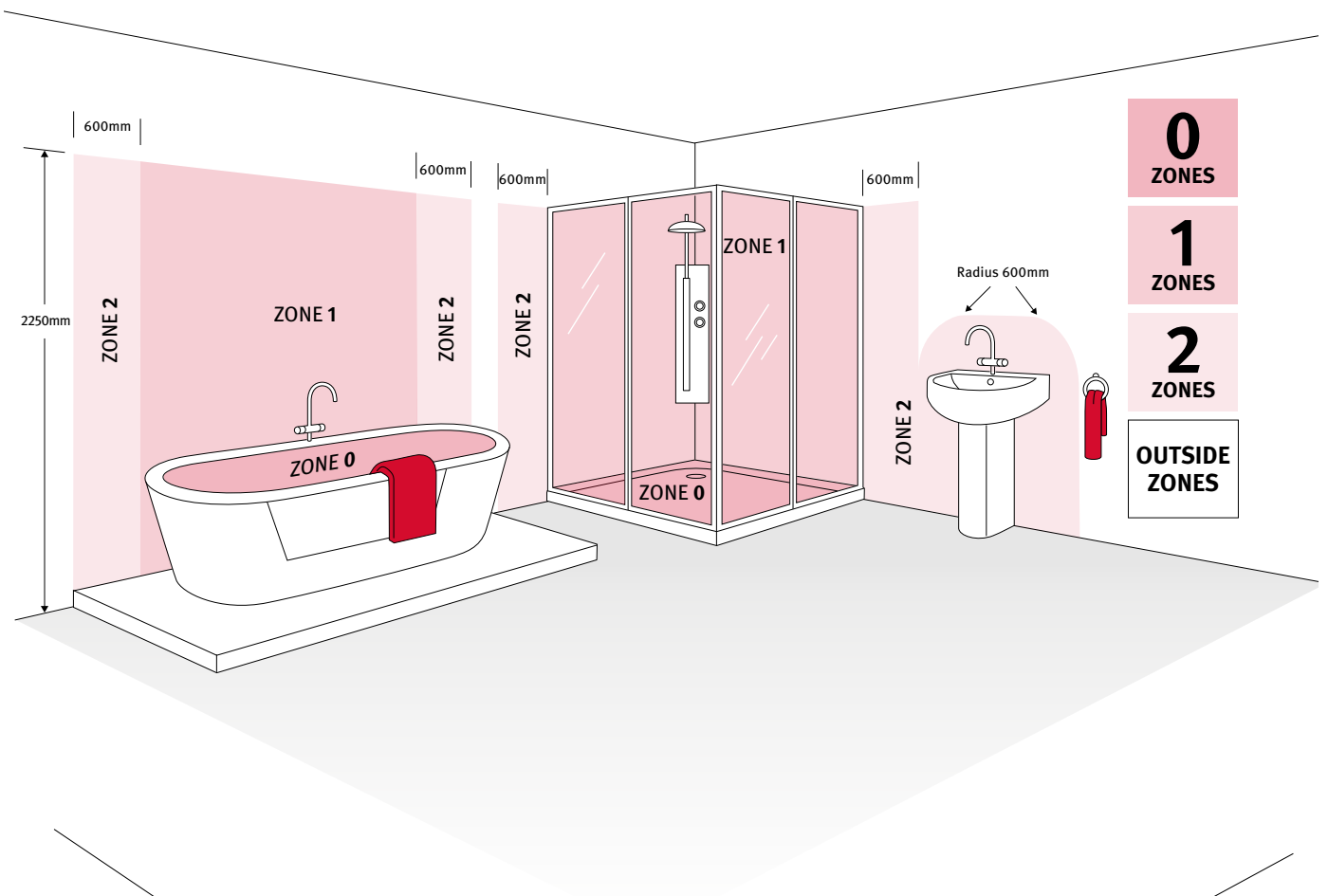

# Training that'll boost your Energy

## Easy does it

Here at Glow-worm, our training team provides two excellent training courses that aim to enhance your Glow-worm Energy product knowledge and help to keep you up to date with any industry changes.



## Energy installation, commissioning and servicing

### Entry Level

Our experienced trainer will guide you through commissioning, system set-up and maintenance so you feel confident installing and maintaining the Energy range, including:

- Pre-installation checks
- Product specification
- Control options
- System accessories

## Energy expert, diagnostics and fault finding

### Expert Level

This course will cover how to diagnose various symptoms using the interface menu and main component testing of the Energy range. A step-by-step process using a combination of boiler status, sequence of operation, and electrical tests assists you in gaining all the knowledge you need, including:

- Component identification
- Boiler drain down
- Safe component removal and replacement
- Electrical testing of the main components



## Our locations

For more information on our courses or to visit one of our UK Centres of Excellence: Phone: 0345 601 8885 or email: [training@glow-worm.co.uk](mailto:training@glow-worm.co.uk)

**Belper**  
Nottingham Road  
Belper  
Derbyshire  
DE56 1JT

**Bristol**  
Unit 1390  
Aztec West  
Almondsbury  
Bristol  
BS32 4RX

**Cambridge**  
Ground Floor  
7400 Building  
Cambridge Research  
Park Waterbeach  
Cambridge  
CB25 9TL

**Elland**  
Unit D1  
Lowfields Business  
Park Elland  
West Yorkshire  
HX5 9DG

**Farnborough**  
Ground Floor (West)  
Templer  
25 Templer Avenue  
Farnborough Business  
Park Farnborough  
Hampshire  
GU14 6FE

**Glasgow**  
Maxim 1  
2 Parklands Way  
Eurocentral  
Glasgow  
Lanarkshire  
ML1 4WR

**Maidstone**  
6 Alexander Grove  
Kings Hill  
West Malling  
Maidstone  
Kent  
ME19 4XR

**North East**  
Unit 7H  
Southwick  
Industrial Estate  
Hylton Road  
Sunderland  
SR5 3TX

# Imagine having 400 mates on every job

We want all our installers to make the most of all of our products and ensure their customers are happy. So, we're always on hand with the support you need. With a 400-strong UK team comprising engineers, call centre staff and technical support, we can solve queries quicker than the contestants on University Challenge.

## Technical help

If you have a technical question, get a straightforward solution by contacting our technical helpline on 01773 828 300, emailing [technical@glow-worm.co.uk](mailto:technical@glow-worm.co.uk) or visiting our website.

## Genuine high-quality spares

- Spares available for up to 15-years after production ends
- Nationwide spares stockists with over 500 locations
- Next-day delivery service for emergency orders – contact spares on 0345 602 0262 or [spares@glow-worm.co.uk](mailto:spares@glow-worm.co.uk)

## Nationwide after-sales service

- Providing technical help and after-sales service online, over the phone and on the road
- 250 engineers based around the UK, carrying over 1,500 different spare parts
- 97% first time fix rate

For our service department please use the contact details below.

# 0330 100 7678

[customerservice@glow-worm.co.uk](mailto:customerservice@glow-worm.co.uk)

## Literature for your customers

There are a number of easy ways for you to access Glow-worm product and homeowner literature:

- Call 01773 596 105
- Download online at [glow-worm.co.uk](http://glow-worm.co.uk) or from Club Energy

# Thousands of spares in your pocket

Spare parts are like films: the originals are always the best. Original Glow-worm spare parts comply fully with industry standards and safety tests because they're tested in conjunction with the boilers they're manufactured for. You can have confidence they'll work every time and with availability for up to 15-years after product manufacture ends, you'll always find what you need.

Our spareCHECK app puts information about our original parts in the palm of your hands, offering:

- Online & offline
- Exploded device views
- Over 4,000 pictures
- Product weights
- Serial number scanning
- Part "where used"



Search 'spareCHECK' on the app stores or scan the QR code:



# Support to keep you glowing

At any moment, something can happen to put you and your business in a tough situation. To help ensure you can always offer your customers the best service possible and keep Britain glowing, Glow-worm is dedicated to making sure you have all the support you need from financial security to wellbeing at all times.

## SUPPORT YOUR EARNINGS

As the business landscape changes, we're constantly adapting to give you new tools that help you and your business. We maintain strong partnerships with other industry-leading companies, and offer Club Energy members business clinics on YouTube with advice from a wide variety of experts.



Support your earnings

## SUPPORT YOUR LEARNING

To ensure you keep moving in the right direction, we have developed a series of online training courses you can access from the comfort of your living room. These interactive courses range from product overviews and introductions to low carbon technologies and best practice techniques.



Support your learning

## SUPPORT YOUR WELLBEING

Our commitment to you goes far beyond simply providing the best products and services for you and your customers. To us, your wellbeing and the wellbeing of others is our main priority. That's why we're giving you support and advice on how to look after yourself mentally, and spot the signs of when others also need a helping hand.



Support your wellbeing

For more information about the support we offer through the tools and services above, visit [www.glow-worm.co.uk/trade](http://www.glow-worm.co.uk/trade)

# Club Energy

## A club you can get into wearing work boots

Club Energy, our loyalty scheme for installers, is a pretty exclusive place. Although there aren't any dress codes or entry fees, there is a tool bag full of benefits, from cash rewards to homeowner leads. You'll also get the chance to win a place on our amazing, all-expenses-paid Mystery Trip.

## Join today and make the most of:

- Cash and credit rewards
- Extended product guarantees
- Training courses
- Homeowner leads
- Access to our Mystery Trip promotion
- The Plumbing Toolbox app, making it easy to register boilers, keep track of the latest offers and news, and more
- Club Energy members will get access to priority numbers for technical and service help

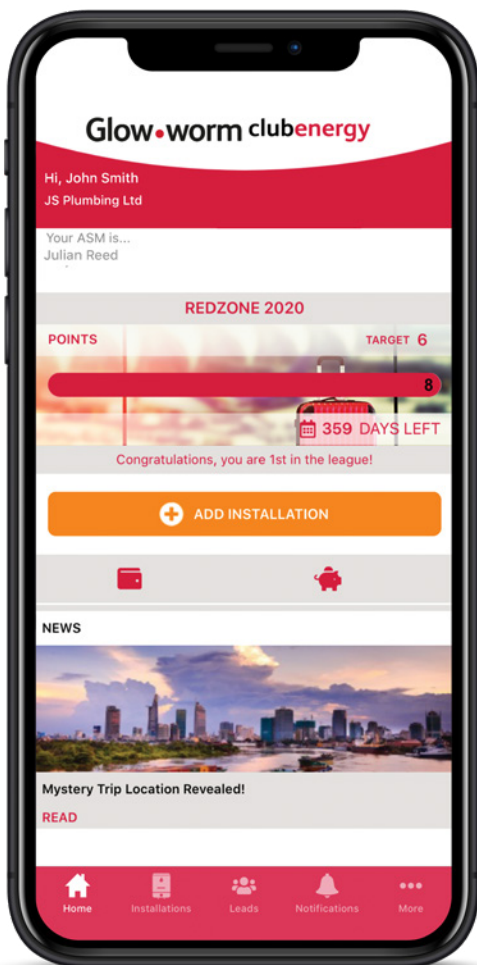

Sign up now at  
[glow-worm.co.uk/clubenergy](https://glow-worm.co.uk/clubenergy)

# What is the Mystery Trip?

The Mystery Trip gives you the opportunity to earn the holiday of a lifetime in an exotic, secret location. Win a spot, and you could be riding snowmobiles across glaciers or sipping cocktails on a pristine beach. All you have to do to get there is install eligible Glow-worm products.

When you sign up, you'll get your own points target, which is tailored to your type of business, and be put into a league. Register the products you install on Club Energy and you'll start clocking up points towards your target, with the aim to get in and stay in the red zone. And look out for special promotions throughout the year to help you get there even quicker.

## MYSTERY TRIP

[glow-worm.co.uk/mysterytrip](https://glow-worm.co.uk/mysterytrip)



**Head office**

01773 824639

info@glow-worm.co.uk

**Literature**

01773 596105

literature@glow-worm.co.uk

**Service department**

0330 100 7678

customerservice@glow-worm.co.uk

**Installer technical support**

01773 828300

technical@glow-worm.co.uk

**Training**

0345 601 8885

training@glow-worm.co.uk

**Spare parts**

0345 602 0262

spares@glow-worm.co.uk

**Club Energy**

0330 678 1414

clubenergy-support@glow-worm.co.uk

**Glow-worm**

Nottingham Road

Belper

Derbyshire

DE56 1JT

 @glow\_wormclub @GlowWormHeating @glowworm\_uk

glow-worm.co.uk

GWBROB2BENGY0820