

## INDEX

|  |     |
|--|-----|
| 1. KEY .....   | 32  |
| 2. GENERAL .....   | 32  |
| 2.1 Safety .....   | 32  |
| 2.2 Responsibility.....  | 32  |
| 2.3 Particular warnings.....                                   | 33  |
| 3. PRODUCT DESCRIPTION.....                                    | 33  |
| 4. PUMPED LIQUIDS .....  | 34  |
| 5. APPLICATIONS .....  | 34  |
| 6. TECHNICAL DATA .....  | 34  |
| 7. MANAGEMENT.....   | 35  |
| 7.1 Storage.....   | 35  |
| 7.2 Transport .....  | 35  |
| 7.3 Weight.....  | 35  |
| 8. INSTALLATION – EVOSTA2, EVOSTA3.....                        | 35  |
| 8.1 Mechanical installation.....                               | 36  |
| 8.2 User Interface Position .....                              | 36  |
| 8.3 Rotation of the user interface .....                       | 38  |
| 8.4 Non-return valve.....                                      | 39  |
| 8.5 Insulating the pump body (only for Evosta3).....           | 39  |
| 9. ELECTRICAL CONNECTIONS.....                                 | 40  |
| 9.1 Power supply connection.....                               | 41  |
| 10. START.....   | 42  |
| 10.1 Degassing the pump.....                                   | 43  |
| 10.2 Automatic Degassing .....                                 | 43  |
| 11. FUNCTIONS.....   | 44  |
| 11.1 Regulating Modes .....                                    | 44  |
| 11.1.1 Regulation with Proportional Differential Pressure..... | 44  |
| 11.1.2 Regulation with Constant Differential Pressure.....     | 45  |
| 11.1.3 Regulation with constant curve .....                    | 45  |
| 12. CONTROL PANEL.....   | 46  |
| 12.1 Elements on the Display.....                              | 46  |
| 12.2 Graphic Display.....                                      | 46  |
| 13. FACTORY SETTINGS.....                                      | 49  |
| 14. TYPES OF ALARM .....                                       | 49  |
| 15. INSTALLATION – EVOSTA2 SOL .....                           | 49  |
| 15.1 Mechanical installation.....                              | 49  |
| 15.2 User Interface Position .....                             | 50  |
| 15.3 Rotation of the user interface .....                      | 51  |
| 15.4 Non-return valve.....                                     | 52  |
| 16. ELECTRICAL CONNECTIONS.....                                | 52  |
| 16.1 Power supply connection.....                              | 53  |
| 17. START.....   | 53  |
| 17.1 Degassing the pump.....                                   | 54  |
| 18. FUNCTIONS.....   | 54  |
| 18.1 Regulating Modes .....                                    | 54  |
| 18.1.1 Regulation with Proportional Differential Pressure..... | 54  |
| 18.1.2 Regulation with constant curve .....                    | 55  |
| 19. CONTROL PANEL.....   | 55  |
| 19.1 Elements on the Display.....                              | 55  |
| 19.2 Settings of the pump operating mode .....                 | 56  |
| 20. FACTORY SETTINGS.....                                      | 57  |
| 21. PWM SIGNAL.....  | 57  |
| 22. TYPES OF ALARM .....                                       | 57  |
| 23. MAINTENANCE .....  | 58  |
| 24. DISPOSAL .....   | 58  |
| 25. DIMENSIONS .....   | 699 |
| 26. PERFORMANCE CURVES.....                                    | 702 |

**INDEX OF FIGURES**

Figure 1: Pumped liquids, warnings and operating conditions .....33  
 Figure 2: Mounting EVOSTA2 or EVOSTA3 .....36  
 Figure 3: Assembly position .....36  
 Figure 4: Positions of the user interface .....37  
 Figure 5: Positions of the user interface .....38  
 Figure 6: Changing the position of the user interface .....38  
 Figure 7: Insulating the pump body .....39  
 Figure 8: Venting of the pump .....43  
 Figure 9: Automatic venting of the pump .....43  
 Figure 10: Display.....46  
 Figure 11: Evosta3 Display.....47  
 Figure 12: Mounting EVOSTA2 SOL .....49  
 Figure 13: Assembly position .....50  
 Figure 14: Positions of the user interface .....51  
 Figure 15: Changing the position of the user interface .....51  
 Figure 16 .....53  
 Figure 17: Venting of the pump .....54  
 Figure 18: Display.....55

**INDEX OF TABLES**

Table 1: Functions .....33  
 Table 2: Technical data .....34  
 Table 3: Maximum head (Hmax) and maximum flow rate (Qmax) of EVOSTA2, EVOSTA3, EVOSTA2 SOL circulators .....35  
 Table 4: Mounting the Evosta3 connector .....41  
 Table 5: Mounting the Evosta2 connector .....42  
 Table 6: Pump operating modes .....48  
 Table 7: Types of Alarm .....49  
 Table 8: Pump operating modes .....56  
 Table 9: Types of Alarm .....57

## 1. KEY

The frontispiece shows the version of this document in the form **Vn.x**. This version indicates that the document is valid for all software versions of the device **n.y**. For example: V3.0 is valid for all Sw: 3.y.

In this document the following symbols will be used to avoid situations of danger:



Situation of **general danger**. Failure to respect the instructions that follow may cause harm to persons and property.



Situation of **electric shock hazard**. Failure to respect the instructions that follow may cause a situation of grave risk for personal safety.

## 2. GENERAL



**Read this documentation carefully before installation.**

**Skilled personnel:** Installation must be carried out by competent, skilled personnel in possession of the technical qualifications required by the specific legislation in force. The term skilled personnel means persons whose training, experience and instruction, as well as their knowledge of the respective standards and requirements for accident prevention and working conditions, have been approved by the person in charge of plant safety, authorizing them to perform all the necessary activities, during which they are able to recognize and avoid all dangers. (Definition for technical personnel IEC 364).

The appliance may not be used by children under 8 years old or by persons with reduced physical, sensory or mental capacities, or who lack experience or knowledge, unless they are under supervision or after they have received instructions concerning the safe use of the appliance and the understanding of the dangers involved. Children must not play with the appliance.



**Ensure that the product has not suffered any damage during transport or storage. Check that the outer casing is unbroken and in excellent conditions.**

### 2.1 Safety

Use is allowed only if the electric system is in possession of safety precautions in accordance with the regulations in force in the country where the product is installed.

### 2.2 Responsibility

The Manufacturer does not vouch for correct operation of the machine or answer for any damage that it may cause if it has been tampered with, modified and/or run outside the recommended work range or in contrast with other indications given in this manual.

### 2.3 Particular warnings



Always switch off the mains power supply before working on the electrical or mechanical part of the system. Wait for the warning lights on the control panel to go out before opening the appliance. The capacitor of the direct current intermediate circuit remains charged with dangerously high voltage even after the mains power has been turned off. Only firmly cabled mains connections are admissible. The appliance must be earthed (IEC 536 class 1, NEC and other applicable standards).



Mains terminals and motor terminals may still have dangerous voltage when the motor is stopped.



If the power cable is damaged, it must be replaced by the technical assistance service or by qualified personnel, so as to avoid any risk.

### 3. PRODUCT DESCRIPTION

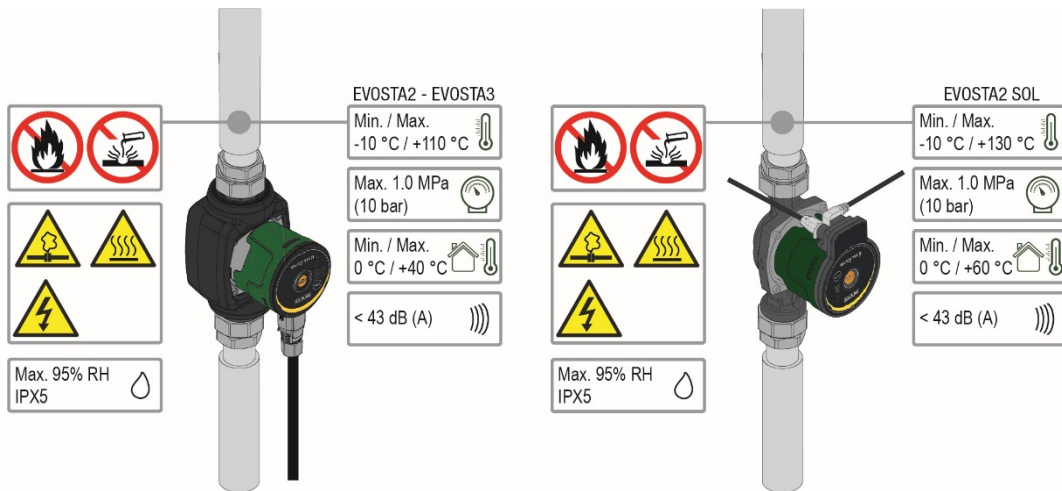

Figure 1: Pumped liquids, warnings and operating conditions

The circulators in the EVOSTA2, EVOSTA3 and EVOSTA2 SOL series represent a complete range of circulators. These installation and operating instructions describe EVOSTA2, EVOSTA3 and EVOSTA2 SOL models. The type of model is indicated on the pack and on the identification plate.

The table below shows the EVOSTA2, EVOSTA3 and EVOSTA2 SOL models with built-in functions and features.

| Functions/features     | EVOSTA 2 | EVOSTA 3 | EVOSTA2 SOL |
|------------------------|----------|----------|-------------|
| Proportional pressure  | •        | •        | •           |
| Constant pressure      | •        | •        | •           |
| Constant curve         | •        | •        |             |
| Dry-running protection |          | •        |             |
| Automatic degassing    |          | •        |             |

Table 1: Functions

## 4. PUMPED LIQUIDS

Clean, free from solids and mineral oils, not viscous, chemically neutral, close to the properties of water (max. glycol contents 30%, 50% EVOSTA2 SOL).

## 5. APPLICATIONS

**EVOSTA2, EVOSTA3, EVOSTA2 SOL** series circulators allow integrated adjustment of the differential pressure which enables the circulator performance to be adapted to the actual requirements of the system. This determines considerable energy saving, a greater possibility of control of the system, and reduced noise.

**EVOSTA2, EVOSTA3, EVOSTA2 SOL** circulators are designed for the circulation of:

- water in heating and conditioning systems.
- water in industrial water circuits.
- domestic water **only for the versions with bronze pump body**.

**EVOSTA2, EVOSTA3, EVOSTA2 SOL** circulators are self-protected against:

- Overloads
- Lack of phase
- Excess temperature
- Over-voltage and under-voltage

## 6. TECHNICAL DATA

|                                 |                                       |                             |
|---------------------------------|---------------------------------------|-----------------------------|
| Supply voltage                  | 1x230 V(+/-10%), 50/60 Hz             |                             |
| Absorbed power                  | See electrical data plate             |                             |
| Maximum current                 | See electrical data plate             |                             |
| Grade of protection             | IPX5                                  |                             |
| Protection class                | F                                     |                             |
| TF Class                        | TF 110                                |                             |
| Motor protector                 | No external motor protector is needed |                             |
| Maximum environment temperature | 40 °C                                 | 60°C EVOSTA2 SOL            |
| Liquid temperature              | -10 °C ÷ 110 °C                       | -10 °C ÷ 130 °C EVOSTA2 SOL |
| Flow rate                       | See Table 3                           |                             |
| Head                            | See Table 3                           |                             |
| Maximum working pressure        | 1.0 Mpa – 10 bar                      |                             |
| Minimum working pressure        | 0.1 Mpa – 1 bar                       |                             |
| Lpa [dB(A)]                     | ≤ 43                                  |                             |

Table 2: Technical data

### Designation index

(example)

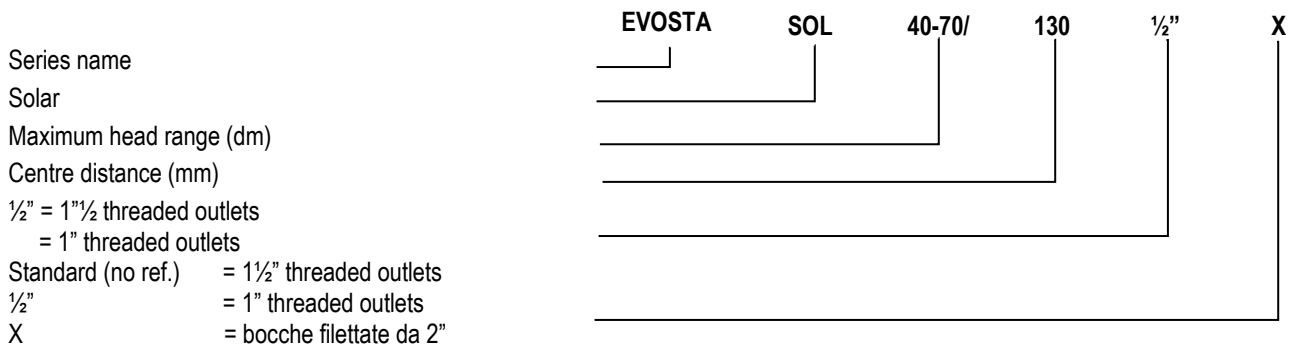

| EVOSTA2, EVOSTA3, EVOSTA2 SOL | Hmax [m] | Qmax [m <sup>3</sup> /h] |
|-------------------------------|----------|--------------------------|
| EVOSTA2 40-70/xxx M230/50-60  | 6,9      | 3,6                      |
| EVOSTA2 80/xxx M230/50-60     | 8        | 4,2                      |
| EVOSTA3 40/xxxM230/50-60      | 4        | 2,9                      |
| EVOSTA3 60/xxx M230/50-60     | 6        | 3,6                      |
| EVOSTA3 80/xxx M230/50-60     | 8        | 4,2                      |
| EVOSTA2 75/xxx SOL            | 7,5      | 4                        |
| EVOSTA2 105/xxx SOL           | 10,5     | 3,6                      |
| EVOSTA2 145/xxx SOL           | 14,5     | 3,6                      |

Table 3: Maximum head (Hmax) and maximum flow rate (Qmax) of EVOSTA2, EVOSTA3, EVOSTA2 SOL circulators

## 7. MANAGEMENT

### 7.1 Storage

All the circulators must be stored in a dry covered place, with possibly constant air humidity, free from vibrations and dust. They are supplied in their original pack in which they must remain until the time of installation. If this is not the case, accurately close the suction and delivery mouth.

### 7.2 Transport

Avoid subjecting the products to needless impacts and collisions. To lift and transport the circulator use lifting devices with the aid of the pallet supplied with it (if contemplated).

### 7.3 Weight

The adhesive plate on the packaging indicates the total weight of the circulator.

## 8. INSTALLATION – EVOSTA2, EVOSTA3



Always switch off the mains power supply before working on the electrical or mechanical part of the system. Wait for the warning lights on the control panel to go out before opening the appliance. The capacitor of the direct current intermediate circuit remains charged with dangerously high voltage even after the mains power has been turned off.

Only firmly cabled mains connections are admissible. The appliance must be earthed (IEC 536 class 1, NEC and other applicable standards).



Ensure that the voltage and frequency on the data plate of the EVOSTA2, EVOSTA3 circulator are the same as those of the power mains.

## 8.1 Mechanical installation

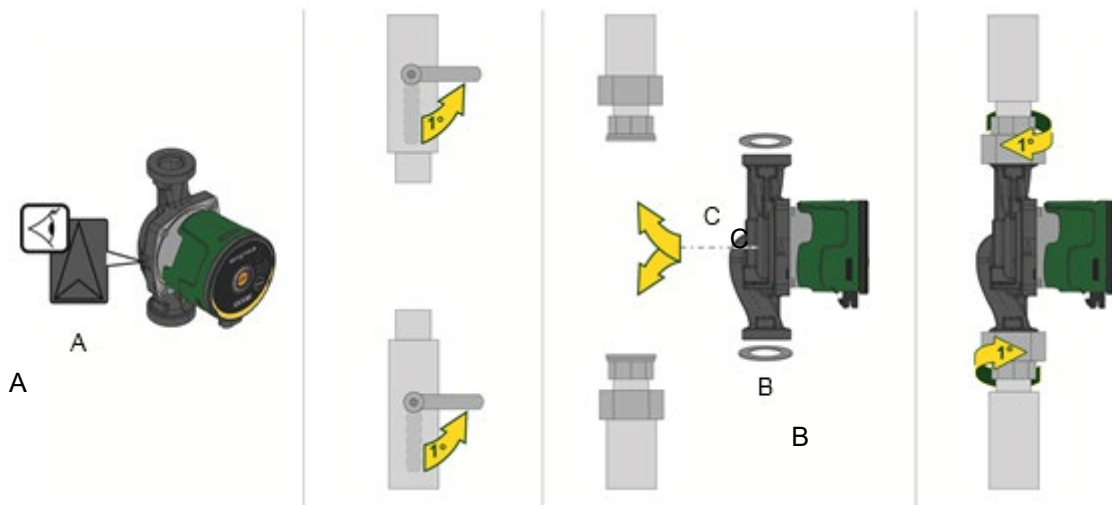

Figure 2: Mounting EVOSTA2 or EVOSTA3

The arrows on the pump housing indicate the flow direction through the pump. See fig. 1, pos. A.

1. Fit the two gaskets when you mount the pump in the pipe. See fig. 1, pos. B.
2. Install the pump with a horizontal motor shaft. See fig. 1, pos. C.
3. Tighten the fittings.

## 8.2 User Interface Position



Always install the EVOSTA2, EVOSTA3 circulator with the motor shaft in a horizontal position.  
Install the electronic control device in a vertical position.

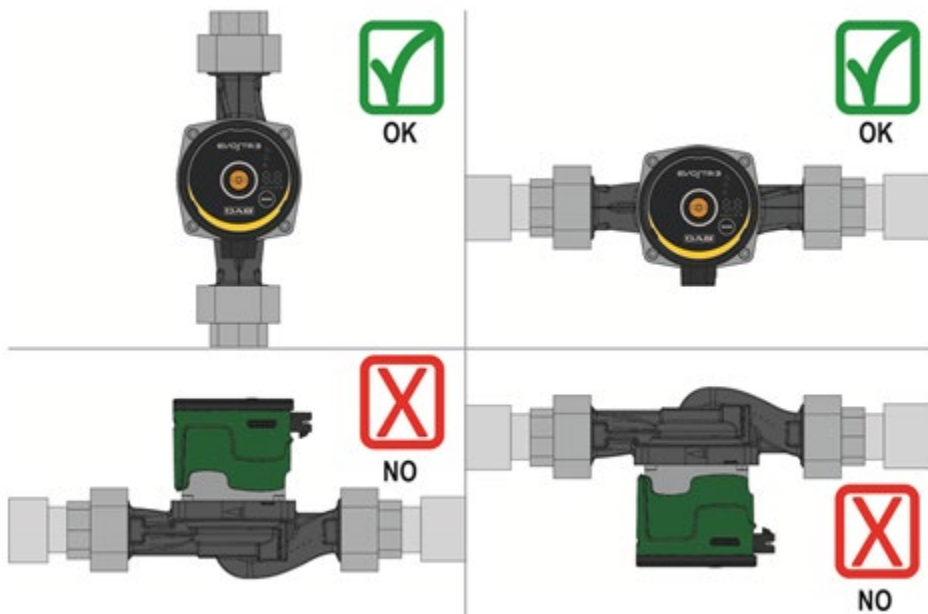

Figure 3: Assembly position

- The circulator may be installed in heating and conditioning systems on either the delivery pipe or the return pipe; the arrow marked on the pump body indicates the direction of flow.
- Install the circulator as far as possible above the minimum boiler level and as far as possible from bends, elbows and junction boxes.
- To facilitate control and maintenance operations, install an interception valve both on the suction pipe and on the delivery pipe.

- Before installing the circulator, accurately flush the system with only water at 80°C. Then drain the system completely to eliminate any harmful substance that may have got into circulation.
- Avoid mixing additives derived from hydrocarbons and aromatic products with the circulating water. It is recommended that the addition of antifreeze, where necessary, should not exceed 30%.
- In the event of heat insulation use the special kit (if provided) and ensure that the condensate draining holes in the motor casing are not closed or partly blocked.
- In the case of maintenance, always use a set of new gaskets.



**Never insulate the electronic control device.**

### 8.2.1 Positioning of the user interface in heating and domestic hot water systems

It is possible to position the user interface with the cable facing to the left, to the right, or downwards.

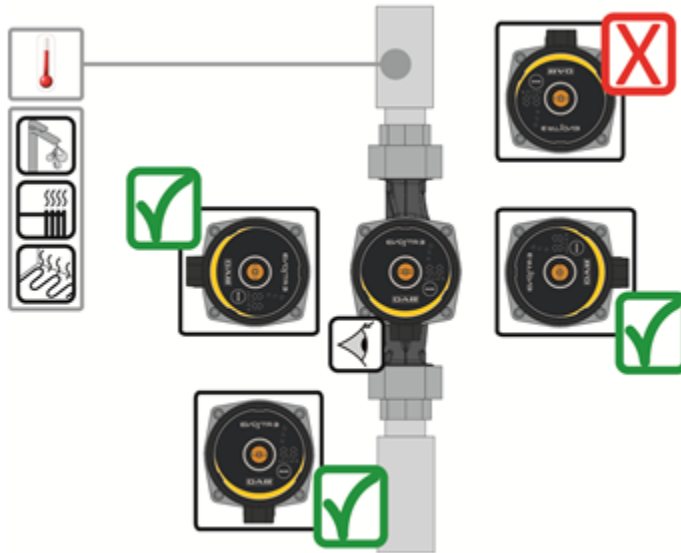

Figure 4: Positions of the user interface

### 8.2.2 Positioning of the user interface in conditioning and cold water systems

The user interface can be positioned only with the cable facing downwards.

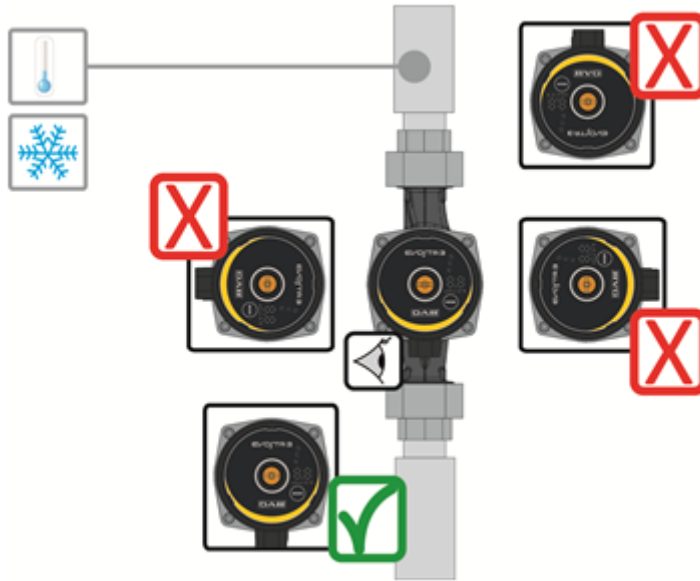

Figure 5: Positions of the user interface

### 8.3 Rotation of the user interface

If the circulator is installed on pipes in a horizontal position, it will be necessary to rotate the interface with the respective electronic device through 90 degrees in order to maintain the grade of IP protection and to allow the user a more convenient interaction with the graphic interface.



**Before rotating the circulator, ensure that it has been completely drained.**

To rotate the EVOSTA2, EVOSTA3 circulator, proceed as follows:

1. Remove the 4 fixing screws of the circulator head.
2. Rotate the motor casing with the electronic control device through 90 degrees clockwise or counterclockwise, as necessary.
3. Reassemble and tighten the 4 screws that fix the circulator head.



**The electronic control device must always remain in vertical position!**

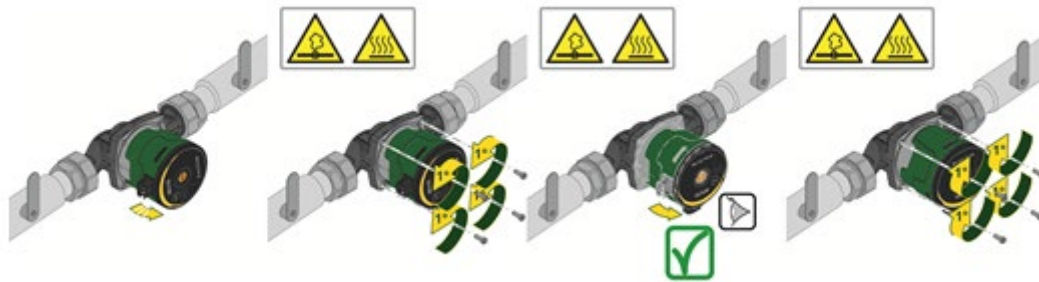

Figure 6: Changing the position of the user interface



**ATTENTION**  
Water at high temperature.  
High temperature.



**ATTENTION**  
System under pressure  
- Before dismantling the pump, empty the system or close the interception valves on both sides of the pump. The pumped liquid may be at a very high temperature and high pressure.

#### 8.4 Non-return valve

If the system is equipped with a non-return valve, ensure that the minimum pressure of the circulator is always higher than the valve closing pressure.

#### 8.5 Insulating the pump body (only for Evosta3)

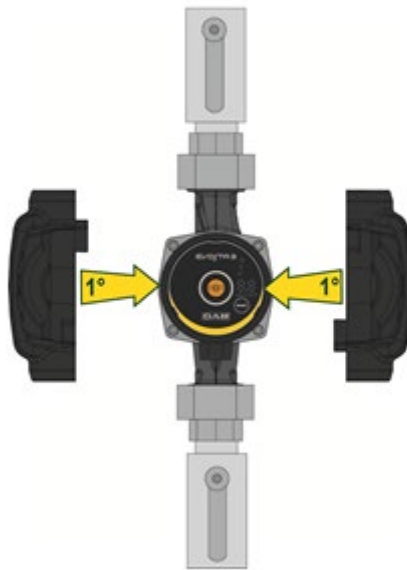

Figure 7: Insulating the pump body

It is possible to reduce the loss of heat from the EVOSTA3 pump by insulating the pump body with the insulating shells supplied with the pump. See fig.9



**Do not insulate the electronic box and do not cover the control panel**

## 9. ELECTRICAL CONNECTIONS

The electrical connections must be made by expert, qualified personnel.



**ATTENTION! ALWAYS RESPECT THE LOCAL SAFETY REGULATIONS.**



Always switch off the mains power supply before working on the electrical or mechanical part of the system. Wait for the warning lights on the control panel to go out before opening the appliance. The capacitor of the direct current intermediate circuit remains charged with dangerously high voltage even after the mains power has been turned off.

Only firmly cabled mains connections are admissible. The appliance must be earthed (IEC 536 class 1, NEC and other applicable standards).



**THE SYSTEM MUST BE CORRECTLY AND SAFELY EARTHED!**



It is advised to install a correctly dimensioned differential switch to protect the system, type: class A with adjustable leakage current, selective.

The automatic differential switch must be marked with the following symbols:

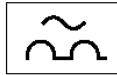

- The circulator does not require any external motor protection.
- Ensure that the supply voltage and frequency are the same as the values indicated on the electrical data plate of the circulator.

9.1 Power supply connection

EVOSTA3

| Phase        | 1  | 2  | 3  |
|--------------|--|--|--|
| Action       | Unscrew the cable gland nut and extract the terminal board from the connector, releasing it from the side clips. | Rotate the terminal board through 180°.  | Fit nut and connector on the cable. Strip the wires as indicated in the figure. Connect the wires to the terminal board, respecting the phase, neutral and earth |
| Illustration |                                |     |   |
| Phase        | 4  | 5  |  |
| Action       | Insert the wired terminal board in the cable gland, securing it with the side clips. Screw on the locking nut.   | Connect the wired connector to the pump, securing it with the rear hook.             |  |
| Illustration |                               |  |  |

Table 4: Mounting the Evosta3 connector

EVOSTA2

| Phase        | 1  | 2  | 3   |
|--------------|--|--|---|
| Action       | Unscrew the cable gland nut and extract the terminal board from the connector. | Remove the retaining screw.  | Fit nut and connector on the cable. Strip the wires as indicated in the figure. Connect the wires to the terminal board, respecting the phase, neutral and earth. |
| Illustration |  |  |   |
| Phase        | 4  | 5  |   |
| Action       | Insert the wired terminal board in the cable gland. Screw on the locking nut.  | Connect the wired connector to the pump and tighten the retaining screw. |   |
| Illustration |  |  |   |

Table 5: Mounting the Evosta2 connector

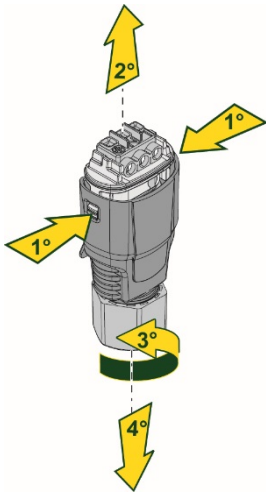
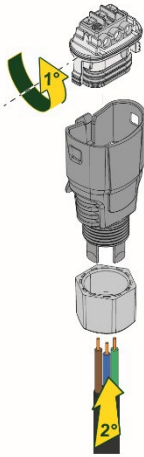
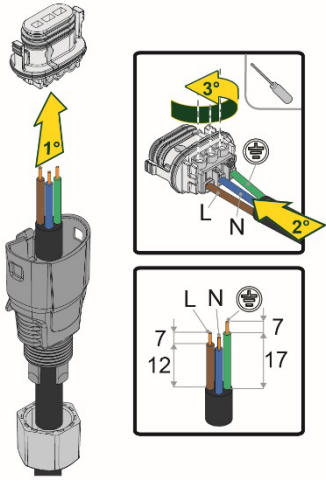
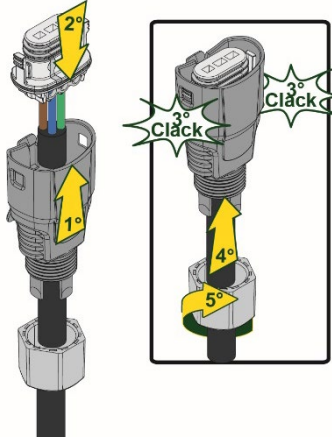
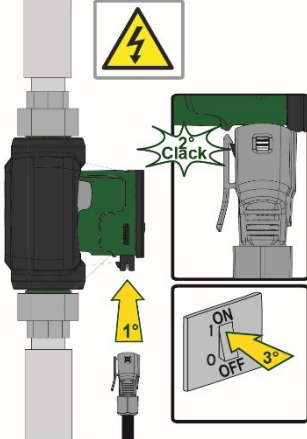
10. START



All the starting operations must be performed with the cover of the EVOSTA2, EVOSTA3 control panel closed.

Start the system only when all the electrical and hydraulic connections have been completed.

Avoid running the circulator when there is no water in the system.



As well as being at a high temperature and pressure, the fluid in the system may also be in the form of steam. DANGER OF SCALDING!

It is dangerous to touch the circulator. DANGER OF SCALDING!

Once all the electrical and hydraulic connections have been made, fill the system with water and if necessary with glycol (for the maximum glycol percentage see par. 3) and feed the system.

Once the system has been started it is possible to modify the operating modes to adapt better to the plant requirements (see par.12).

### 10.1 Degassing the pump

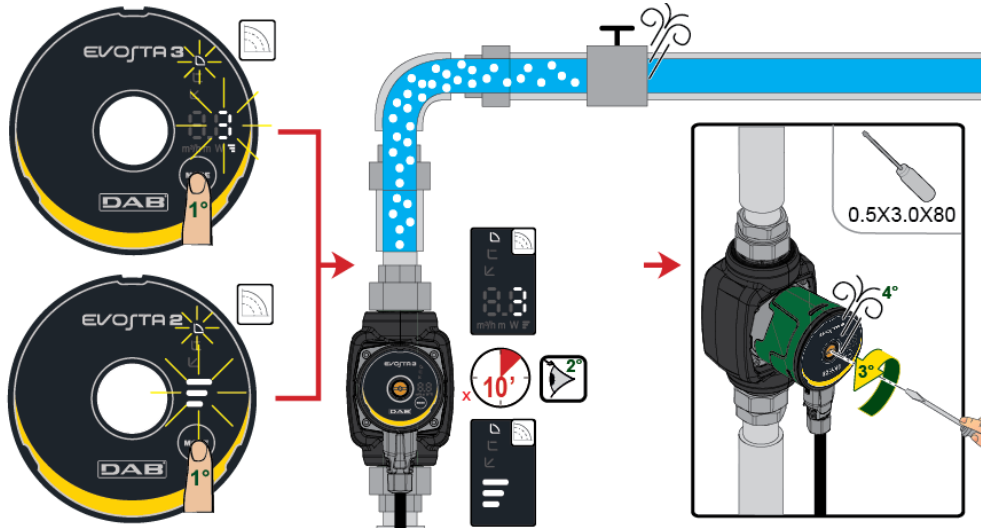

Figure 8: Venting of the pump



**Always vent the pump before starting!**

**The pump must never run when dry.**

### 10.2 Automatic Degassing

Automatic degassing occurs only for the Evosta3 pump. Hold down the Mode key for 3" and the function starts: 1 minute at maximum speed, then it passes to the set mode.

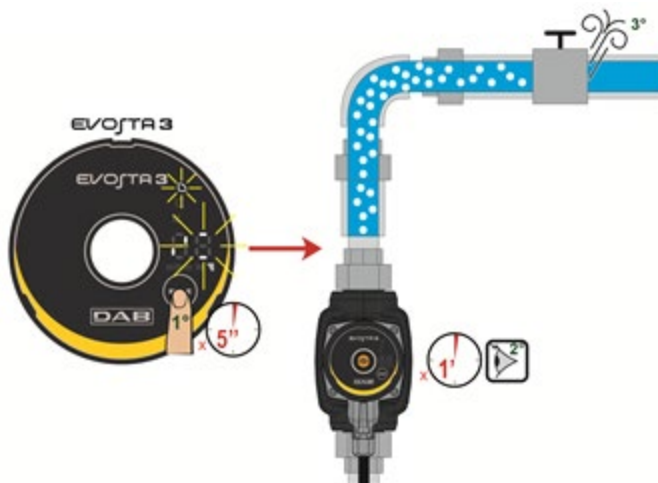

Figure 9: Automatic venting of the pump

## 11. FUNCTIONS

### 11.1 Regulating Modes

EVOSTA2, EVOSTA3 circulators allow the following regulating modes depending on plant requirements:

- Proportional differential pressure regulation depending on the flow present in the plant.
- Constant differential pressure regulation.
- Regulation with constant curve.

The regulating mode may be set through the EVOSTA2, EVOSTA3 control panel.

#### 11.1.1 Regulation with Proportional Differential Pressure

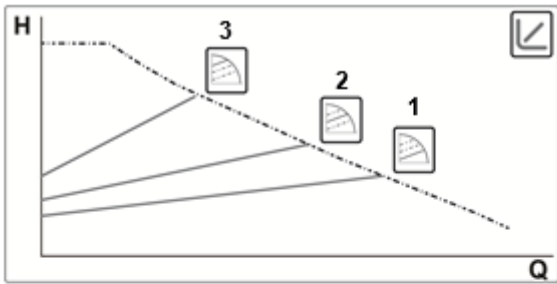

In this regulating mode the differential pressure is reduced or increased as the demand for water decreases or increases. The Hs set point may be set from the display.



Regulation indicated for:

- Heating and conditioning plants with high load losses
- Plants with secondary differential pressure regulator
- Primary circuits with high load losses
- Domestic water recirculating systems with thermostatic valves on the rising columns

#### 11.1.1.1 Regulation with Proportional Differential Pressure –Advanced Menu

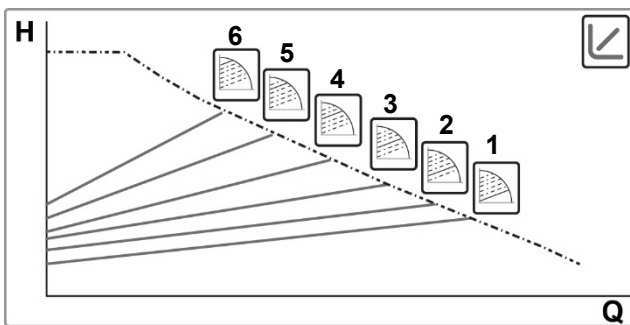

Holding down the Mode key for 20" gives access to the Advanced Menu with the possibility of selecting from 6 curves with proportional differential pressure



### 11.1.2 Regulation with Constant Differential Pressure

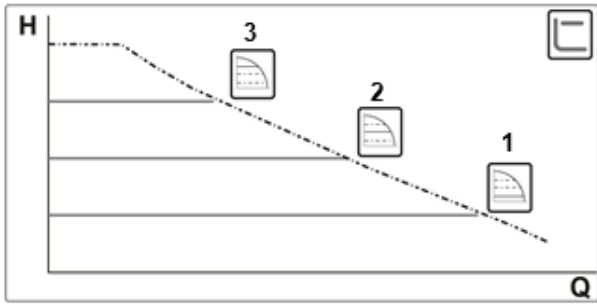

In this regulating mode the differential pressure is kept constant, irrespective of the demand for water, The Hs set point may be set from the display.

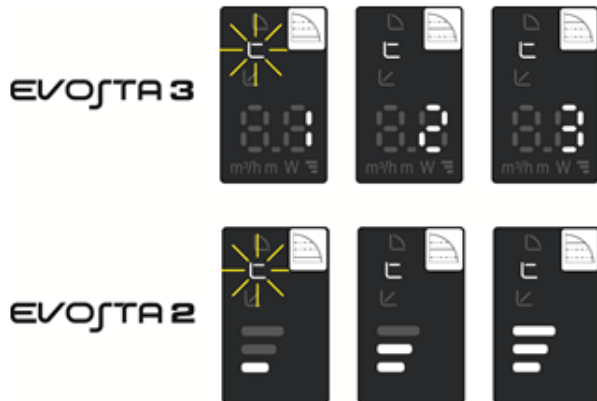

Regulation indicated for:

- Heating and conditioning plants with low load losses
- Single-pipe systems with thermostatic valves
- Plants with natural circulation
- Primary circuits with low load losses
- Domestic water recirculating systems with thermostatic valves on the rising columns

### 11.1.3 Regulation with constant curve

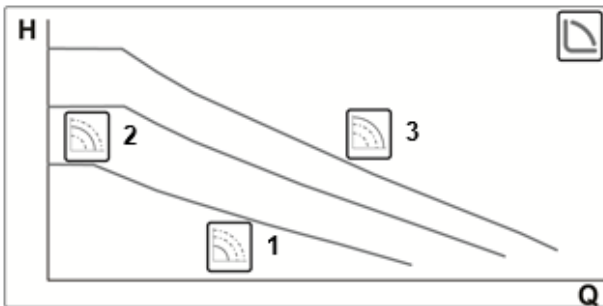

In this regulating mode the circulator works on characteristic curves at a constant speed.



Regulation indicated for heating and conditioning plants with constant flow.

## 12. CONTROL PANEL

The functions of EVOSTA2, EVOSTA3 circulators can be modified by means of the control panel on the cover of the electronic control device.

### 12.1 Elements on the Display

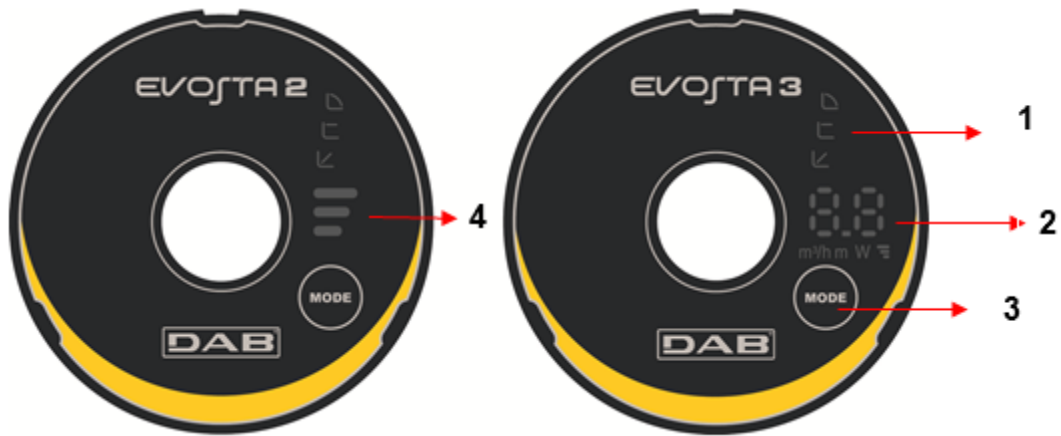



Figure 10: Display

- 1 Luminous segments indicating the type of set curve
- 2 Display showing the instantaneous power absorption in Watt, the flow rate in m<sup>3</sup>/h, the head in metres and the set curve.
- 3 Key for selecting the pump setting
- 4 Luminous segments indicating the set curve

### 12.2 Graphic Display

#### 12.2.1 Luminous segments indicating the pump setting

The pump presents nine setting options that can be selected with the  key. The pump settings are indicated by six luminous segments on the display.

#### 12.2.2 Key for selecting the pump setting



Whenever the  key is pressed, the pump setting is changed. A cycle consists of pressing the key ten times.

### 12.2.3 Display Operation



Figura 11: Evosta3 Display

The Evosta3 circulator has a display that is able to show the following values.

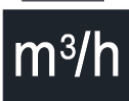
|   |  |
|---|--|
|  | Height of the selected curve (1-2-3)   |
|  | Instantaneous power absorption in Watt |
|  | Instantaneous head in m                |
|  | Instantaneous flow rate in m3/h        |

The values are shown in sequence for 3". Once the viewing cycle is ended, the display switches off and only the operating mode LED remains lit.

If the selection key is pressed within 10", the display performs 6 viewing cycles, then goes into stand-by.

If the key is pressed again within 10", the display performs 11 more viewing cycles to allow a greater reading time.

12.2.4 Settings of the pump operating mode



















|   | EVOSTA3   | EVOSTA2   |  |
|---|---|---|--|
| 1 |    |    | Lower curve with proportional pressure, PP1        |
| 2 |    |    | Intermediate curve with proportional pressure, PP2 |
| 3 |    |    | Higher curve with proportional pressure, PP3       |
| 4 |   |   | Lower curve with constant pressure, CP1            |
| 5 |  |  | Intermediate curve with constant pressure, CP2     |
| 6 |  |  | Higher curve with constant pressure, CP3           |
| 7 |  |  | Lower constant curve, I                            |
| 8 |  |  | Intermediate constant curve, II                    |
| 9 |  |  | Higher constant curve, III                         |

Table 6: Pump operating modes

### 13. FACTORY SETTINGS

Regulating mode: ↖ = Minimum proportional differential pressure regulation

### 14. TYPES OF ALARM

| Alarm Description                 |   |
|-----------------------------------|---|
| <b>No. of curve height blinks</b> | <b>EVOSTA2</b>  |
| 2 Blinks                          | TRIP: loss of motor control, may be caused by incorrect parameters, blocked rotor, disconnected phase, disconnected motor |
| 3 Blinks                          | SHORT CIRCUIT: short circuit on phases or between phase and earth   |
| 4 Blinks                          | OVERRUN: software fault   |
| 5 Blinks                          | SAFETY: safety module error, may be caused by a sudden overcurrent or other hardware faults of the board                  |
| <b>Alarm Code</b>                 | <b>EVOSTA3</b>  |
| E1                                | DRY RUN   |
| E2                                | TRIP: loss of motor control, may be caused by incorrect parameters, blocked rotor, disconnected phase, disconnected motor |
| E3                                | SHORT CIRCUIT: short circuit on phases or between phase and earth   |
| E4                                | OVERRUN: software fault   |
| E5                                | SAFETY: safety module error, may be caused by a sudden overcurrent or other hardware faults of the board                  |

Table 7: Types of Alarm

### 15. INSTALLATION – EVOSTA2 SOL



Always switch off the mains power supply before working on the electrical or mechanical part of the system. Wait for the warning lights on the control panel to go out before opening the appliance. The capacitor of the direct current intermediate circuit remains charged with dangerously high voltage even after the mains power has been turned off.

Only firmly cabled mains connections are admissible. The appliance must be earthed (IEC 536 class 1, NEC and other applicable standards).



Ensure that the voltage and frequency on the data plate of the EVOSTA2 SOL circulator are the same as those of the power mains.

#### 15.1 Mechanical installation

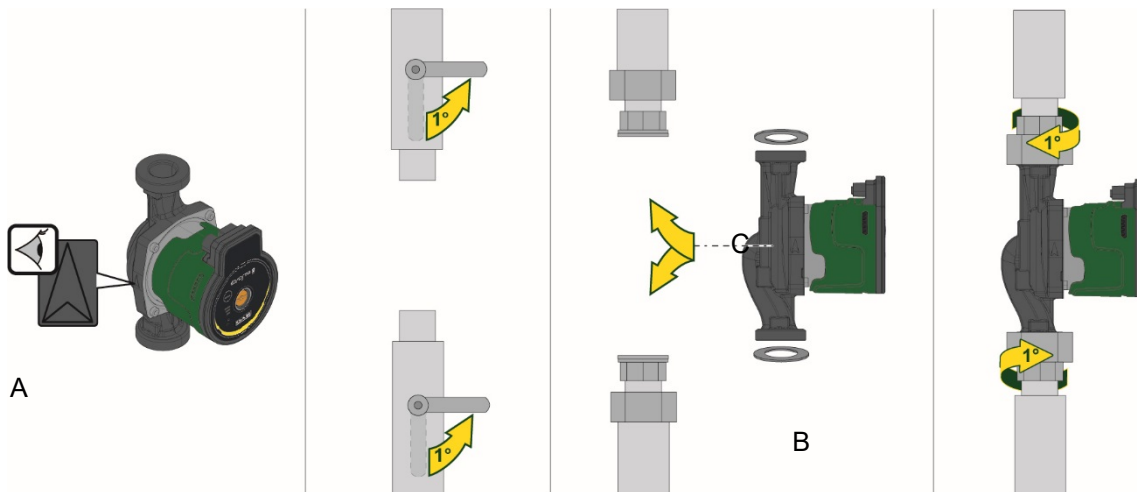

Figure 12: Mounting EVOSTA2 SOL

The arrows on the pump housing indicate the flow direction through the pump. See fig. 1, pos. A.

1. Fit the two gaskets when you mount the pump in the pipe. See fig. 1, pos. B.
2. Install the pump with a horizontal motor shaft. See fig. 1, pos. C.
3. Tighten the fittings.

## 15.2 User Interface Position



**Always install the EVOSTA2 SOL circulator with the motor shaft in a horizontal position.  
Install the electronic control device in a vertical position.**

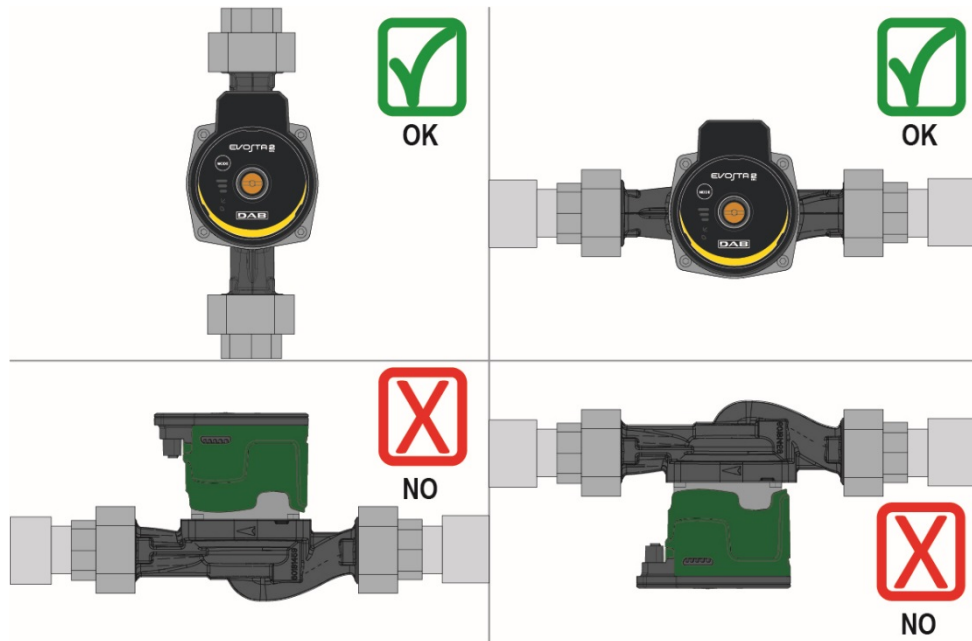

Figure 13: Assembly position

- The circulator may be installed in heating and conditioning systems on either the delivery pipe or the return pipe; the arrow marked on the pump body indicates the direction of flow.
- Install the circulator as far as possible above the minimum boiler level and as far as possible from bends, elbows and junction boxes.
- To facilitate control and maintenance operations, install an interception valve both on the suction pipe and on the delivery pipe.
- Before installing the circulator, accurately flush the system with only water at 80°C. Then drain the system completely to eliminate any harmful substance that may have got into circulation.
- Avoid mixing additives derived from hydrocarbons and aromatic products with the circulating water. It is recommended that the addition of antifreeze, where necessary, should not exceed 30%.
- In the event of heat insulation use the special kit (if provided) and ensure that the condensate draining holes in the motor casing are not closed or partly blocked.
- In the case of maintenance, always use a set of new gaskets.



**Never insulate the electronic control device.**

### 15.2.1 Positioning of the user interface in heating systems

It is possible to position the user interface with the cable facing to the left, to the right, or upwards.

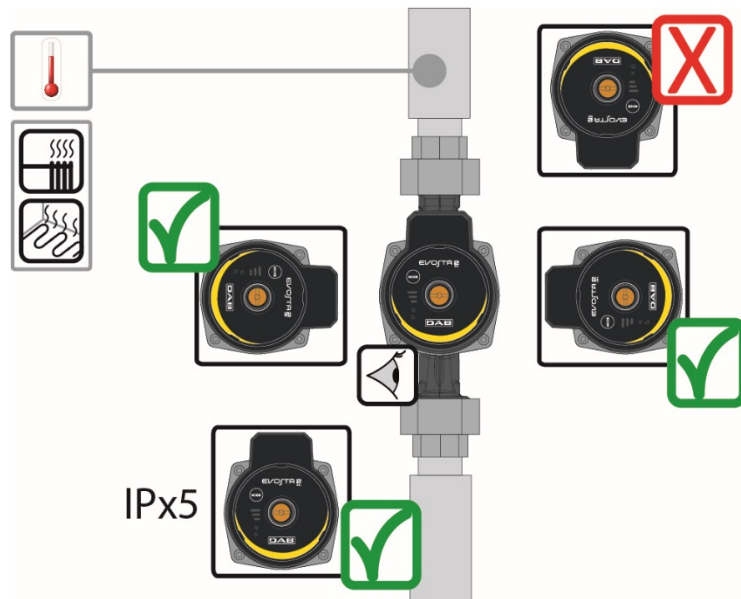

Figure 14: Positions of the user interface

### 15.3 Rotation of the user interface

If the circulator is installed on pipes in a horizontal position, it will be necessary to rotate the interface with the respective electronic device through 90 degrees in order to maintain the grade of IP protection and to allow the user a more convenient interaction with the graphic interface.



**Before rotating the circulator, ensure that it has been completely drained.**

To rotate the EVOSTA2 SOL circulator, proceed as follows:

1. Remove the 4 fixing screws of the circulator head.
2. Rotate the motor casing with the electronic control device through 90 degrees clockwise or counterclockwise, as necessary.
3. Reassemble and tighten the 4 screws that fix the circulator head.



**The electronic control device must always remain in vertical position!**

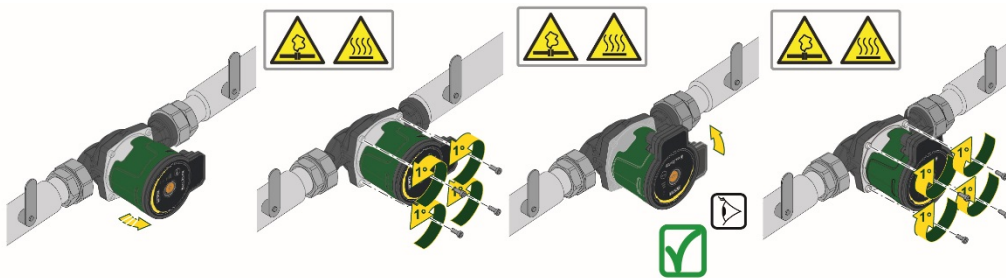

Figure 15: Changing the position of the user interface



**ATTENTION**  
Water at high temperature.  
High temperature.



**ATTENTION**  
System under pressure  
- Before dismantling the pump, empty the system or close the interception valves on both sides of the pump. The pumped liquid may be at a very high temperature and high pressure.

#### 15.4 Non-return valve

If the system is equipped with a non-return valve, ensure that the minimum pressure of the circulator is always higher than the valve closing pressure.

### 16. ELECTRICAL CONNECTIONS

The electrical connections must be made by expert, qualified personnel.



**ATTENTION! ALWAYS RESPECT THE LOCAL SAFETY REGULATIONS.**



Always switch off the mains power supply before working on the electrical or mechanical part of the system. Wait for the warning lights on the control panel to go out before opening the appliance. The capacitor of the direct current intermediate circuit remains charged with dangerously high voltage even after the mains power has been turned off.

Only firmly cabled mains connections are admissible. The appliance must be earthed (IEC 536 class 1, NEC and other applicable standards).



**THE SYSTEM MUST BE CORRECTLY AND SAFELY EARTHED!**



It is advised to install a correctly dimensioned differential switch to protect the system, type: class A with adjustable leakage current, selective.

The automatic differential switch must be marked with the following symbols:



- The circulator does not require any external motor protection.
- Ensure that the supply voltage and frequency are the same as the values indicated on the electrical data plate of the circulator.

## 16.1 Power supply connection

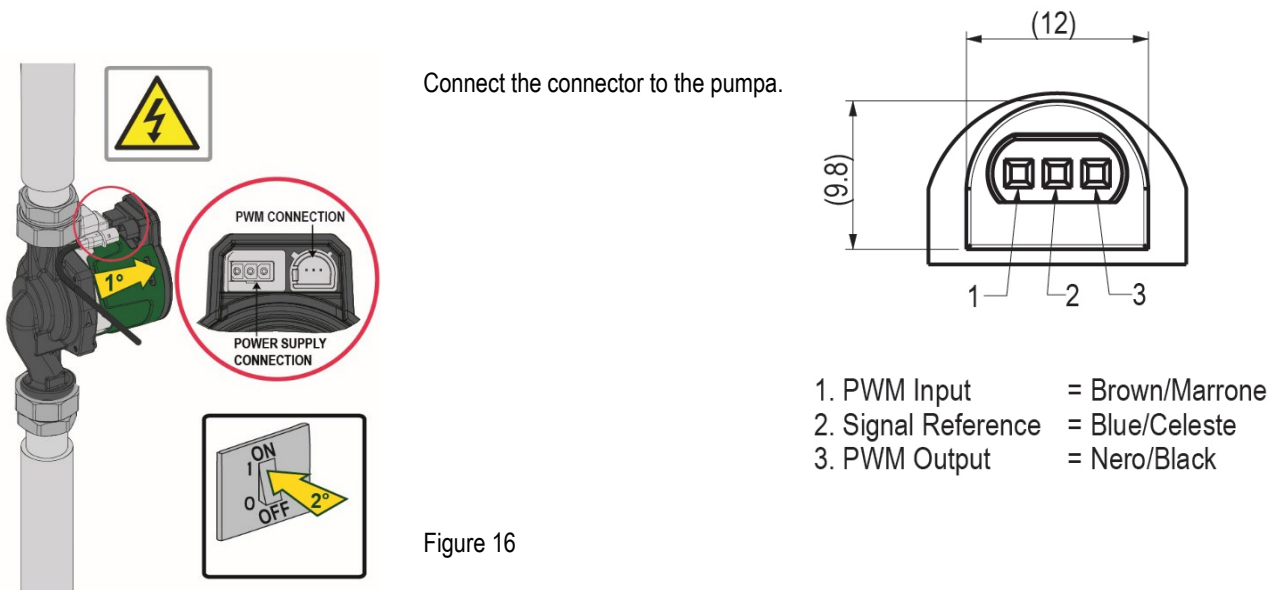

## 17. START



All the starting operations must be performed with the cover of the EVOSTA2 SOL control panel closed.

Start the system only when all the electrical and hydraulic connections have been completed.

Avoid running the circulator when there is no water in the system.



As well as being at a high temperature and pressure, the fluid in the system may also be in the form of steam. **DANGER OF SCALDING!**

It is dangerous to touch the circulator. **DANGER OF SCALDING!**

Once all the electrical and hydraulic connections have been made, fill the system with water and if necessary with glycol (for the maximum glycol percentage see par. 3) and feed the system.

Once the system has been started it is possible to modify the operating modes to adapt better to the plant requirements (see par.12).

## 17.1 Degassing the pump

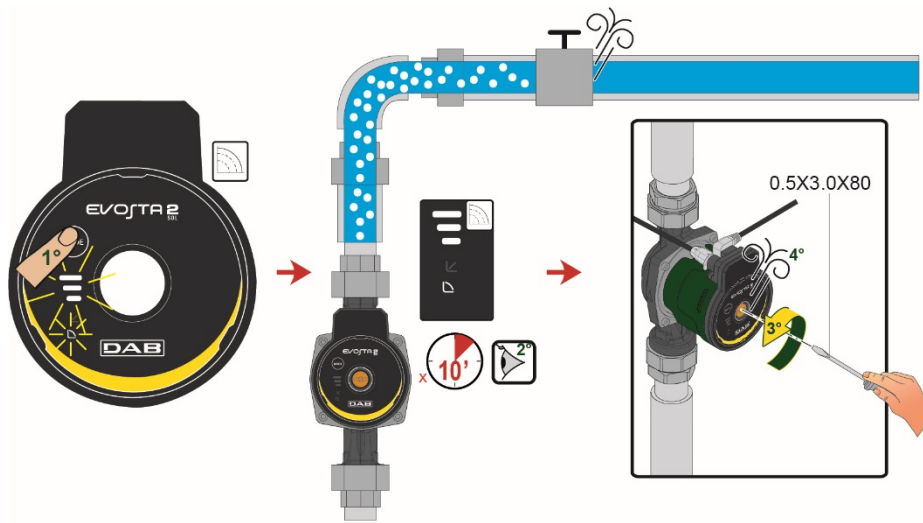

Figure 17: Venting of the pump



Always vent the pump before starting!

The pump must never run when dry.

## 18. FUNCTIONS

### 18.1 Regulating Modes

EVOSTA2 SOL circulators allow the following regulating modes depending on plant requirements:

- Proportional differential pressure regulation depending on the flow present in the plant.
- Regulation with constant curve.

The regulating mode may be set through the EVOSTA2 SOL control panel.

#### 18.1.1 Regulation with Proportional Differential Pressure

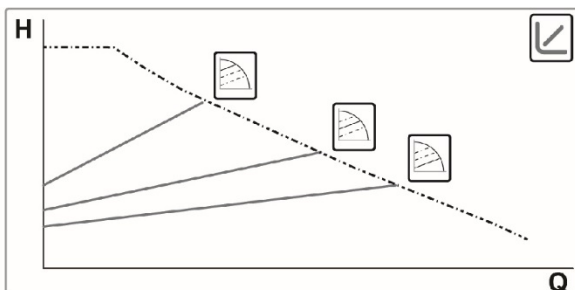

In this regulating mode the differential pressure is reduced or increased as the demand for water decreases or increases. The Hs set point may be set from the display.

Regulation indicated for:

- Heating and conditioning plants with high load losses
- Plants with secondary differential pressure regulator
- Primary circuits with high load losses
- Domestic water recirculating systems with thermostatic valves on the rising columns

EVOSTA 2  
SOL



### 18.1.2 Regulation with constant curve

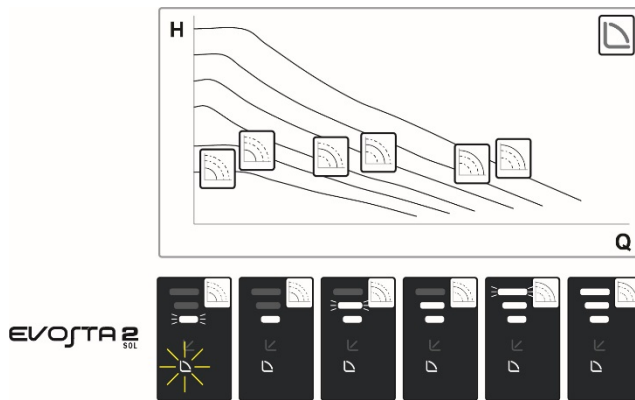

In this regulating mode the circulator works on characteristic curves at a constant speed.

Regulation indicated for heating and conditioning plants with constant flow.

## 19. CONTROL PANEL

The functions of EVOSTA2 SOL circulators can be modified by means of the control panel on the cover of the electronic control device.

### 19.1 Elements on the Display

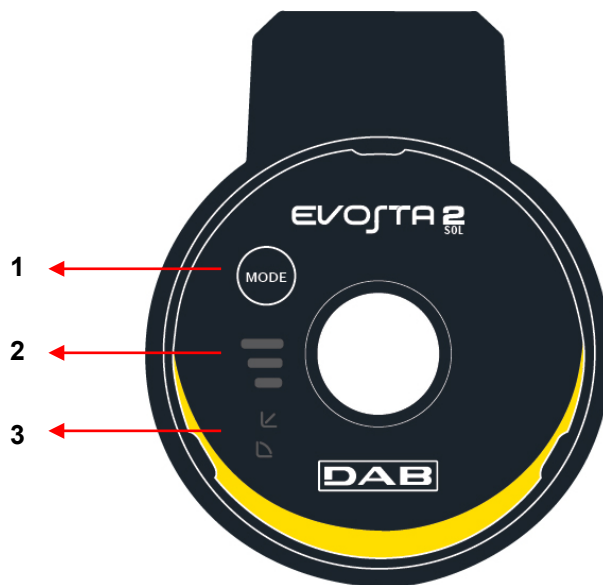

Figure 18: Display

- 1 Key for selecting the pump setting
- 2 Luminous segments indicating the type of set curve
- 3 Luminous segments indicating the set curve

19.2 Settings of the pump operating mode



|   | EVOSTA2 SOL   |  |
|---|---|--|
| 1 |    | Lower curve with proportional pressure, PP1        |
| 2 |    | Intermediate curve with proportional pressure, PP2 |
| 3 |    | Higher curve with proportional pressure, PP3       |
| 4 |   | Constant curve, speed I                            |
| 5 |  | Constant curve, speed II                           |
| 6 |  | Constant curve, speed III                          |
| 7 |  | Constant curve, speed IV                           |
| 8 |  | Constant curve, speed V                            |
| 9 |  | Constant curve, speed VI                           |

Table 8: Pump operating modes

## 20. FACTORY SETTINGS

Regulating mode: ↻ = Minimum proportional differential pressure regulation.

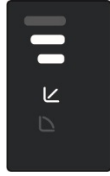
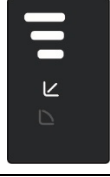
## 21. PWM SIGNAL

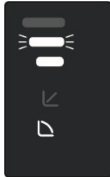
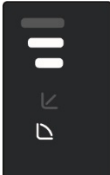
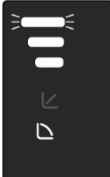
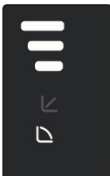
Profile of PWM signal at input of SOLAR version

| Working área      | Duty cicle PWM |
|-------------------|----------------|
| Standby mode      | <5%            |
| Hysteresis área   | ≥5% / <9%      |
| Minimum setpoint  | ≥9% / <16%     |
| Variable setpoint | ≥16% / <90%    |
| Maximum setpoint  | >90% / ≤100%   |

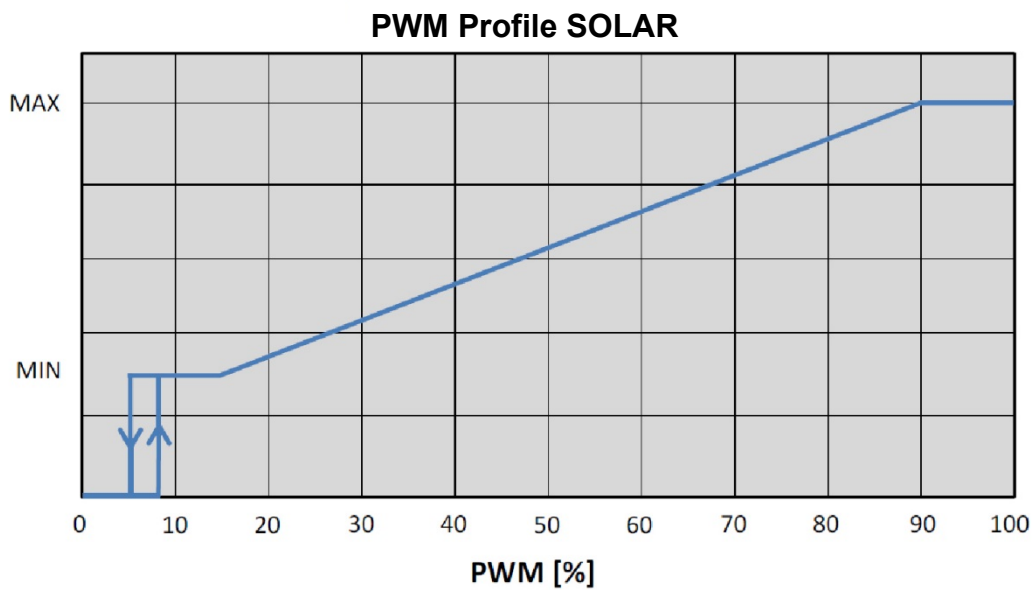

## 22. TYPES OF ALARM

| No. of curve height blinks | Alarm Description   |
|----------------------------|---|
|                            | EVOSTA2   |
| 2 Blinks                   | TRIP: loss of motor control, may be caused by incorrect parameters, blocked rotor, disconnected phase, disconnected motor |
| 3 Blinks                   | SHORT CIRCUIT: short circuit on phases or between phase and earth   |
| 4 Blinks                   | OVERRUN: software fault   |
| 5 Blinks                   | SAFETY: safety module error, may be caused by a sudden overcurrent or other hardware faults of the board                  |

Table 9: Types of Alarm

## 23. MAINTENANCE



Cleaning and maintenance activities must not be carried out by children (under 8 years of age) without supervision by a qualified adult. Before starting any work on the system, before starting to look for faults it is necessary to disconnect the power supply to the pump (take the plug out of the socket) and read the use and maintenance instructions.

## 24. DISPOSAL



This product or its parts must be disposed of in an environment-friendly manner and in compliance with the local regulations concerning the environment; use public or private local waste collection systems.

## INFORMATION

Frequently asked questions (faq) on the ecodesign directive 2009/125/ec establishing a framework for the setting of ecodesign requirements for energy-related products and its implementing regulations: [http://ec.europa.eu/enterprise/policies/sustainable-business/documents/eco-design/guidance/files/20110429\\_faq\\_en.pdf](http://ec.europa.eu/enterprise/policies/sustainable-business/documents/eco-design/guidance/files/20110429_faq_en.pdf)

Guidelines accompanying commission regulations implementing the ecodesign directive: [http://ec.europa.eu/energy/efficiency/ecodesign/legislation\\_en.htm](http://ec.europa.eu/energy/efficiency/ecodesign/legislation_en.htm) - see "circulators"